

Stocked Electro-Mechanical Switches

**DC-18 GHz**

SP3T SEM Series

- Standard Features Include:
Normally Open and Latching Models
TTL Logic Control, Suppression Diodes
- All Models Supplied with
Indicator Circuits

Specifications

SP3T, SMA (F), DC to 18 GHz

MODEL	FEATURES	ACTUATING CURRENT (mA @28Vdc & 25°C)	FREQUENCY RANGE (GHz)	INSERTION LOSS (dB max.)	VSWR (max.)	ISOLATION (dB min.)
SEM133	NORMALLY OPEN / INDICATOR CKT	140	DC-3	0.2	1.2	80
			3-8	0.3	1.3	70
			8-12.4	0.4	1.4	60
			12.4-18	0.5	1.5	60
SEM133D	NORMALLY OPEN / TTL* / SUPPRESSION DIODE / INDICATOR CKT	140	DC-3	0.2	1.2	80
			3-8	0.3	1.3	70
			8-12.4	0.4	1.4	60
			12.4-18	0.5	1.5	60
SEM133T	NORMALLY OPEN / TERMINATED / INDICATOR CKT	140	DC-3	0.2	1.2	80
			3-8	0.3	1.3	70
			8-12.4	0.4	1.4	60
			12.4-18	0.5	1.5	60
SEM133DT	NORMALLY OPEN / TERMINATED / TTL* / SUPPRESSION DIODE / INDICATOR CKT	180	DC-3	0.2	1.2	80
			3-8	0.3	1.3	70
			8-12.4	0.4	1.4	60
			12.4-18	0.5	1.5	60
SEM133LT	PULSE LATCHING / TERMINATED / INDICATOR CKT	300	DC-3	0.2	1.2	80
			3-8	0.3	1.3	70
			8-12.4	0.4	1.4	60
			12.4-18	0.5	1.5	60

* APPLIES TO ALL SWITCHES WITH TTL:

1. Selected position of the switch is controlled by TTL Logic
2. Switch requires only nominal +28 Vdc for coils (additional 5 Vdc is not required)
3. TTL LOGIC LEVEL: Low 0 to .8Vdc High 2.5 to 5.0Vdc
4. TTL LOGIC INPUT CURRENT: Low 0 mA High 1.6 mA max @ 3.85 Vdc

Stocked Electro-Mechanical Switches

Outline Drawings and Schematics Dimensions in inches, unless otherwise specified.

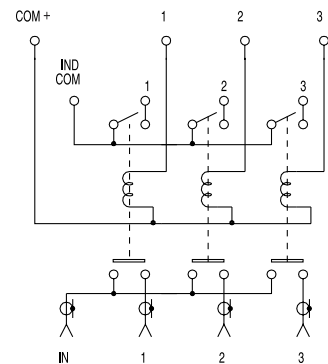
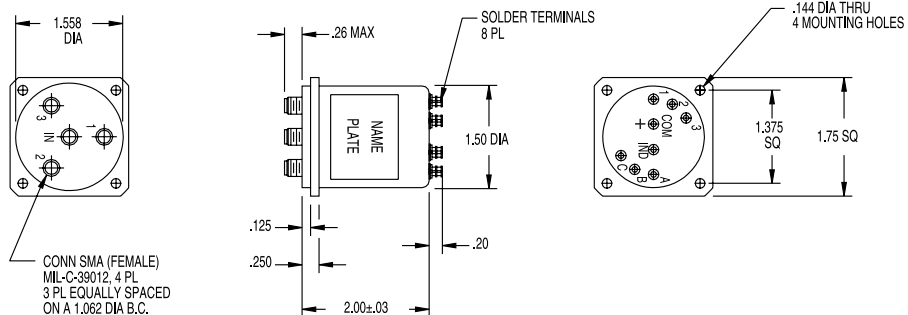

SCHEMATIC SHOWN IN NORMALLY OPEN POSITION

SEM133

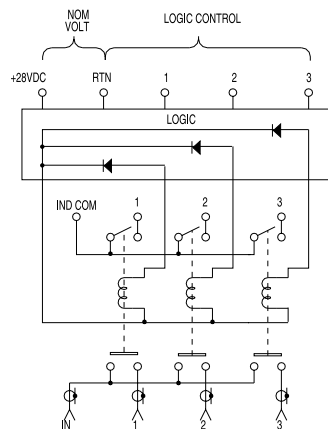
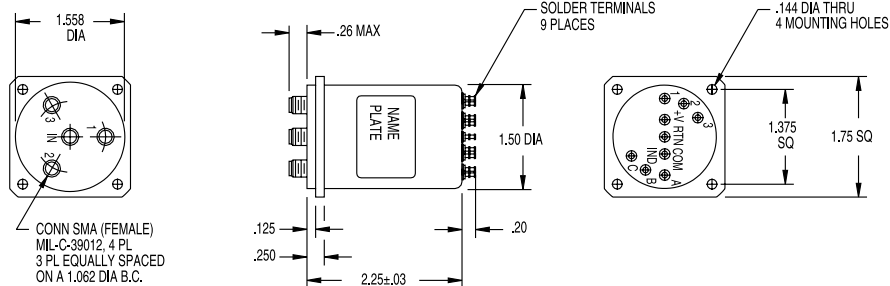

SCHEMATIC SHOWN IN NORMALLY OPEN POSITION

SEM133D

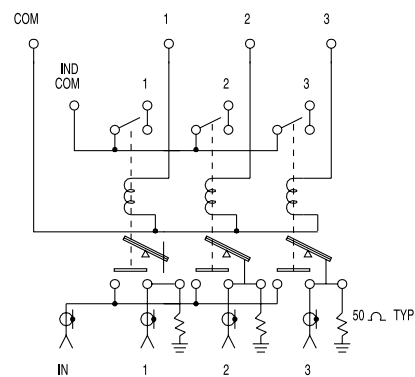
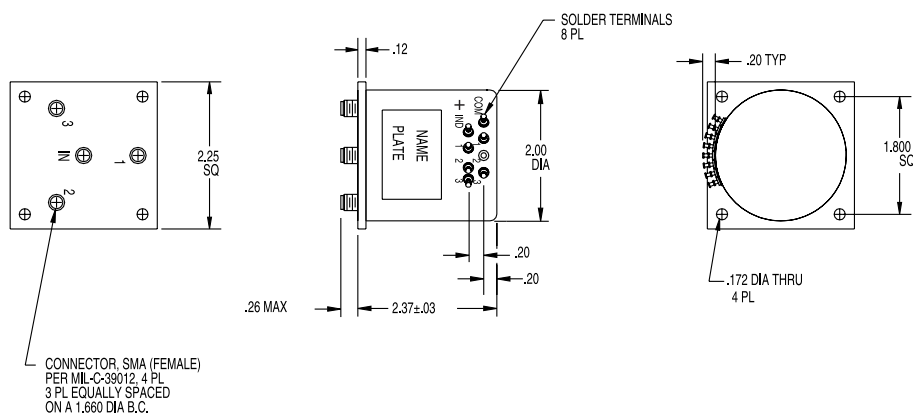

SCHEMATIC SHOWN WITH POSITION 1 CLOSED

SEM133T

Stocked Electro-Mechanical Switches

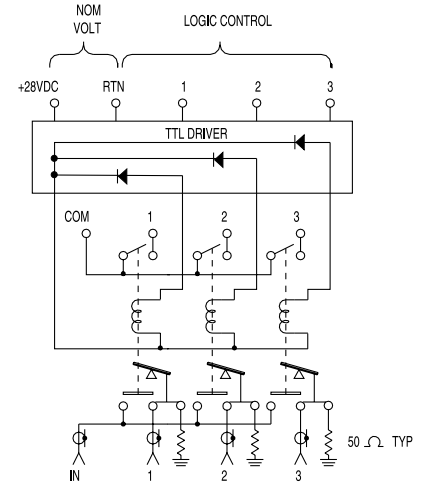
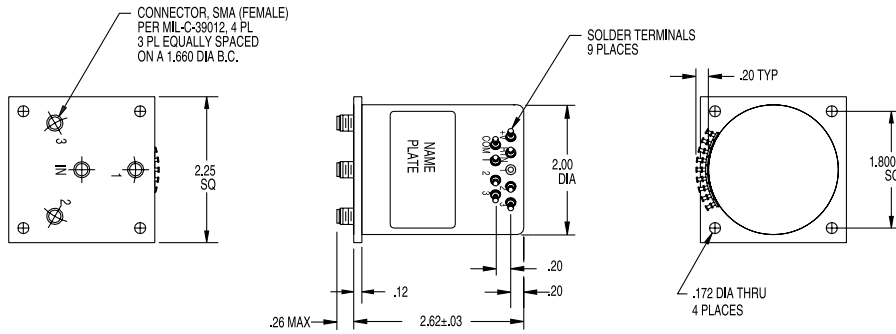

SCHEMATIC SHOWN IN 50 Ω TERMINATED POSITION

SEM133DT

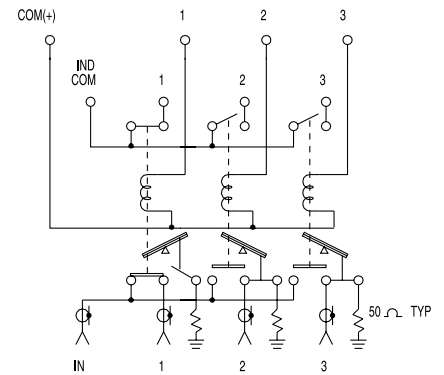
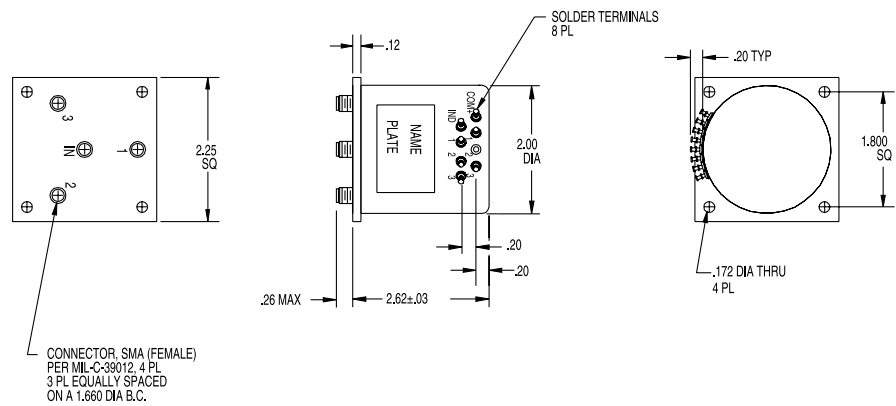

SCHEMATIC SHOWN WITH POSITION 1 CLOSED

SEM133LT

Stocked Electro-Mechanical Switches

Glossary

All switches are bi-directional. Inputs and Outputs are interchangeable.

SP2T – A single pole, double throw switch has one input port and two selectable output ports.

Multiposition Switch – A multiposition switch has one input port and more than two selectable output ports. Unlike some switches, Narda models can be switched directly to any one of the available output positions without sequencing through intervening positions.

Transfer Switch – A transfer switch has two independent paths that operate simultaneously in one of two selected positions.

Failsafe – The switch moves to the closed position when the actuating voltage is applied and always returns to a predetermined position when the voltage is removed.

Latching – Also called Pulse Latching, the switch remains in a preselected position whenever the actuating voltage is removed or interrupted and holds that preselected position until a voltage is applied to another position. This configuration must be pulse controlled with a pulse width of 20 ms to 100 ms duration. Standard polarity is common positive.

Normally Open – All output ports of the switch are disconnected from the input port until a voltage is applied to a selected position.

Terminated Units – Each unused or open output RF port is internally terminated in a 50-ohm resistive load (1W CW max.).

Common Specifications

RF Impedance.....	50 ohms nominal
Actuating Voltage.....	28 Vdc \pm 2 V
Switching Time.....	15 ms (max.)
Switching Sequence.....	Break Before Make
Operating Ambient Temp.....	-35°C to +70°C
Operating Life.....	1 million cycles/position
Designed to meet MIL-S-3928	

TTL – Selected position of the switch is controlled by a TTL Logic High. The switch requires only nominal +28 Vdc (additional 5 Vdc is not required).

TTL Logic Voltage Level:

Low 0 to 0.8 Vdc

High 2.5 to 5.0 Vdc

TTL Logic Input Current:

Low 0 mA

High 1.6 mA max. @ 3.85 Vdc

TTL Units – Transistor-Transistor-Logic circuitry enables the status of the switch to be controlled by the level of TTL logic input.

Suppression Diodes – Fast recovery silicon rectifiers (diodes) connected in parallel with the coils of the switch to suppress any transient voltage that may be generated by the coils.

Indicator Circuitry – A set of internally mounted contacts that allows external monitoring of switch RF status. Some switch series include a steering diode drive due to the electronic indicator.

Solder Terminal – A turret terminal is standard on all switches.

Self De-energizing Circuitry – With this option, a set of internally mounted contacts or electronically generated pulses disconnects the driver voltage as soon as RF contact has been made. This option is only available with latching type switches. Suppression diodes must be specified with this option.



Stocked Electro-Mechanical Switches

Power Handling Capability

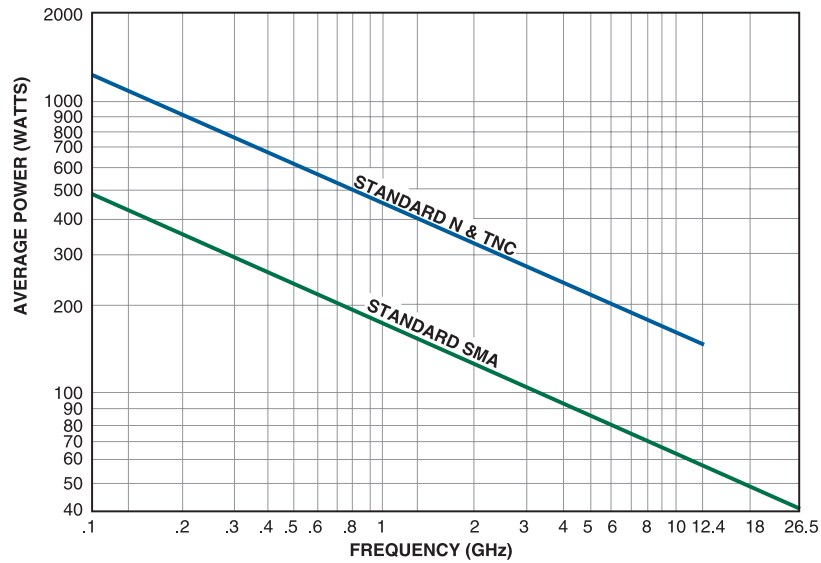

Power Handling Capability of Narda Switches vs. Frequency for Common RF Connectors
(for 25°C ambient temperature, matched 50ohm systems, sea level and cold switching)

For VSWR above 1.1, Derate Power Handling Capability as shown:

VSWR	Derating Factor
1.5	.94
2.0	.88
2.5	.83
3.0	.78
3.5	.73
4.0	.70

