

Stocked Electro-Mechanical Switches

DC-26.5 GHz

SP2T SEM Series

- Standard Features Include:
Latching Models, Failsafe Models,
TTL Logic Control, Indicator Circuits



Specifications

SP2T, SMA (F), DC to 18 GHz

MODEL	FEATURES	ACTUATING CURRENT (mA @28Vdc & 25°C)	FREQUENCY RANGE (GHz)	INSERTION LOSS (dB max.)	VSWR (max.)	ISOLATION (dB min.)
SEM020 SEM020-12 SEM020-24	FAILSAFE	160 275 @ 12V 200 @ 24V	DC-3 3-8 8-12.4 12.4-18	0.2 0.3 0.4 0.5	1.2 1.3 1.4 1.5	80 70 60 60
SEM020L	PULSE LATCHING	200	DC-3 3-8 8-12.4 12.4-18	0.2 0.3 0.4 0.5	1.2 1.3 1.4 1.5	80 70 60 60
SEM123	FAILSAFE / INDICATOR CKT	160	DC-3 3-8 8-12.4 12.4-18	0.2 0.3 0.4 0.5	1.2 1.3 1.4 1.5	80 70 60 60
SEM123D	FAILSAFE / INDICATOR CKT / TTL* / SUPPRESSION DIODE	160	DC-3 3-8 8-12.4 12.4-18	0.2 0.3 0.4 0.5	1.2 1.3 1.4 1.5	80 70 60 60
SEM123L	PULSE LATCHING / INDICATOR CKT	200	DC-3 3-8 8-12.4 12.4-18	0.2 0.3 0.4 0.5	1.2 1.3 1.4 1.5	80 70 60 60
SEM123T	FAILSAFE / INDICATOR CKT / TERMINATED	280	DC-3 3-8 8-12.4 12.4-18	0.2 0.3 0.4 0.5	1.2 1.3 1.4 1.5	80 70 60 60
SEM123LT	PULSE LATCHING / TERMINATED / INDICATOR CKT	280	DC-3 3-8 8-12.4 12.4-18	0.2 0.3 0.4 0.4	1.2 1.3 1.4 1.4	80 70 60 60

Stocked Electro-Mechanical Switches

SP2T, SMA (F), DC to 18 GHz (con't)

MODEL	FEATURES	ACTUATING CURRENT (mA @28Vdc & 25°C)	FREQUENCY RANGE (GHz)	INSERTION LOSS (dB max.)	VSWR (max.)	ISOLATION (dB min.)
SEM123LD	PULSE LATCHING / INDICATOR CKT / TTL*	200	DC-3	0.2	1.2	80
			3-8	0.3	1.3	70
			8-12.4	0.4	1.4	60
			12.4-18	0.5	1.5	60
SEM123DT	FAILSAFE / TERMINATED / INDICATOR CKT / SUPPRESSION DIODE / TTL*	280	DC-3	0.2	1.2	80
			3-8	0.3	1.3	70
			8-12.4	0.4	1.4	60
			12.4-18	0.5	1.5	60
SEM123LDT SEM123LDT-24	PULSE LATCHING / INDICATOR CKT / TERMINATED / TTL* / SELF DE-ENERGIZING	280 325 @ 24V	DC-3	0.2	1.2	80
			3-8	0.3	1.3	70
			8-12.4	0.5	1.4	60
			12.4-18	0.5	1.5	60

SP2T, Type N (F), DC to 12.4 GHz

MODEL	FEATURES	ACTUATING CURRENT (mA @28Vdc & 25°C)	FREQUENCY RANGE (GHz)	INSERTION LOSS (dB max.)	VSWR (max.)	ISOLATION (dB min.)
SEM123N	FAILSAFE / INDICATOR CKT	180	DC-3	0.2	1.2	80
			3-8	0.35	1.35	70
			8-12.4	0.5	1.5	60
SEM123DN	FAILSAFE / INDICATOR CKT / TTL* / SUPPRESSION DIODE	180	DC-3	0.2	1.2	80
			3-8	0.35	1.35	70
			8-12.4	0.5	1.5	60

SP2T, SMA (F), DC to 26.5 GHz

MODEL	FEATURES	ACTUATING CURRENT (mA @28Vdc & 25°C)	FREQUENCY RANGE (GHz)	INSERTION LOSS (dB max.)	VSWR (max.)	ISOLATION (dB min.)
SEM124	FAILSAFE / INDICATOR CKT	160	DC-3	0.2	1.2	80
			3-8	0.3	1.3	70
			8-12.4	0.4	1.4	60
			12.4-18	0.5	1.5	60
			18-26.5	0.7	1.7	50

* APPLIES TO ALL SWITCHES WITH TTL:

1. Selected position of the switch is controlled by TTL Logic
2. Switch requires only nominal +28 Vdc for coils (additional 5 Vdc is not required)
3. TTL LOGIC LEVEL: Low 0 to .8 Vdc High 2.5 to 5.0 Vdc
4. TTL LOGIC INPUT CURRENT: Low 0 mA High 1.6 mA max @ 3.85 Vdc

Stocked Electro-Mechanical Switches

Outline Drawings and Schematics Dimensions in inches, unless otherwise specified.

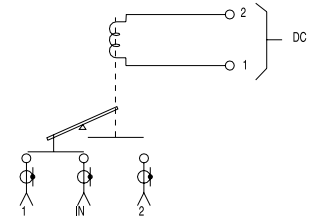
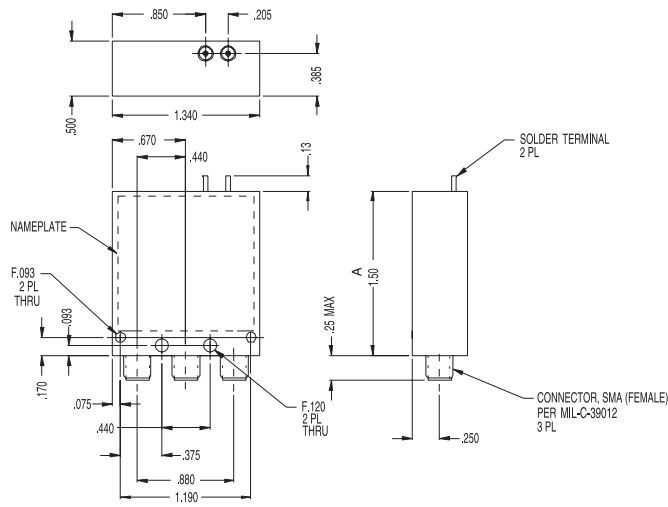

SCHEMATIC SHOWN IN FAILSAFE POSITION

SEM020, SEM020-12, SEM020-24

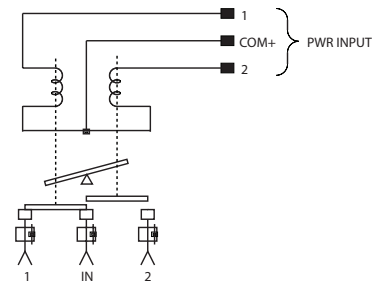
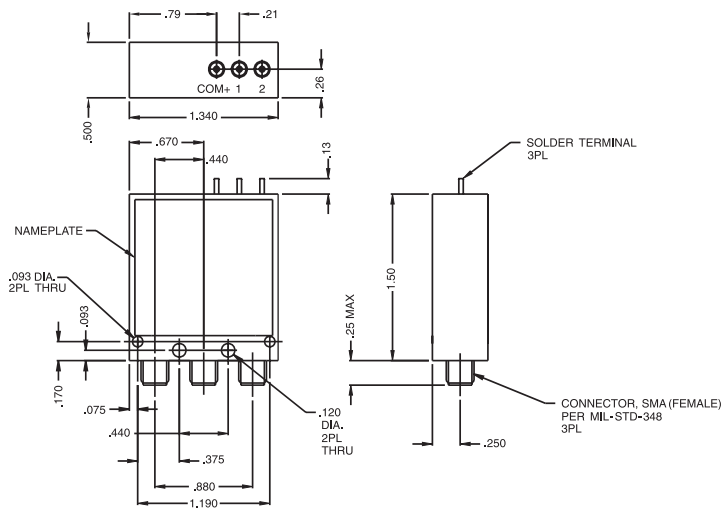

SCHEMATIC SHOWN WITH POSITION 1 CLOSED

SEM020L

Stocked Electro-Mechanical Switches

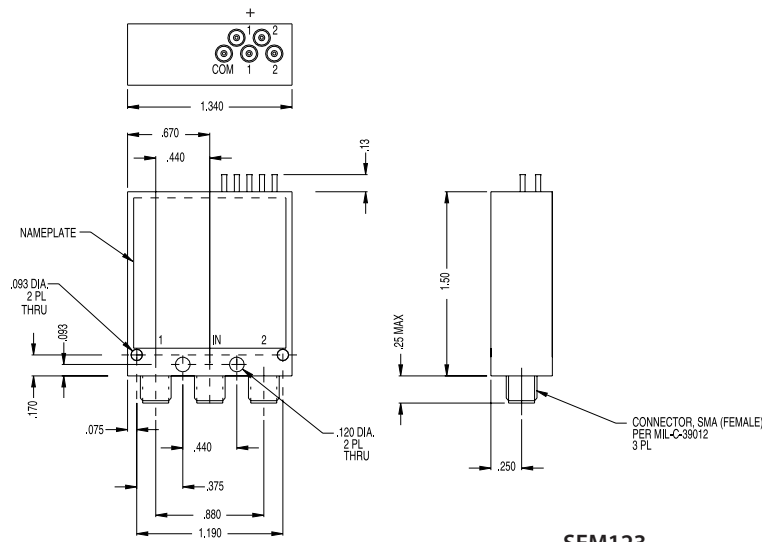

SEM123

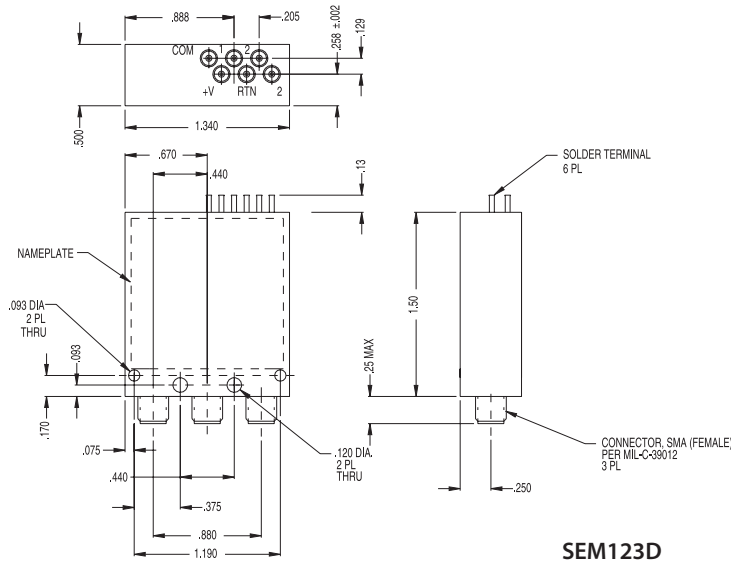
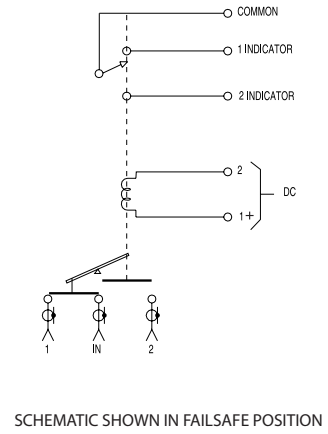

SEM123D

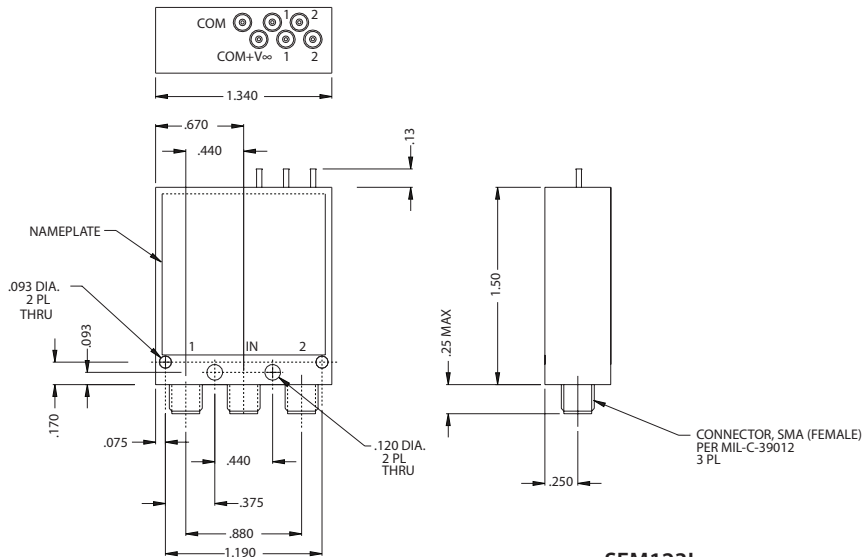
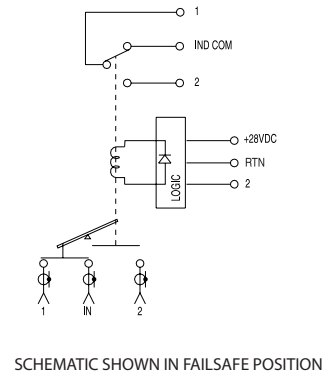

SEM123L

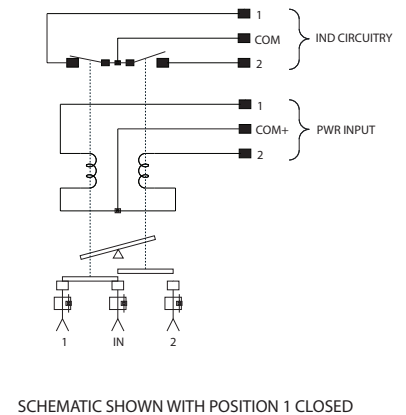

Stocked Electro-Mechanical Switches

Outline Drawings and Schematics Dimensions in inches, unless otherwise specified.

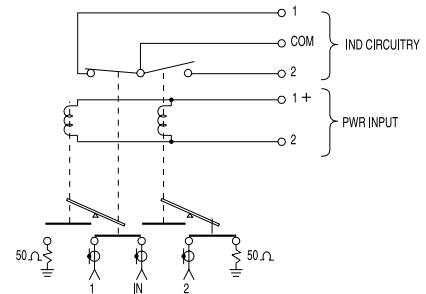
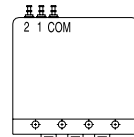
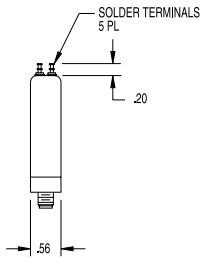
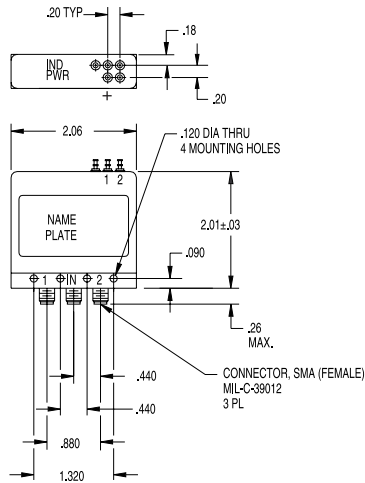

SCHEMATIC SHOWN WITH POSITION 1 CLOSED

SEM123T

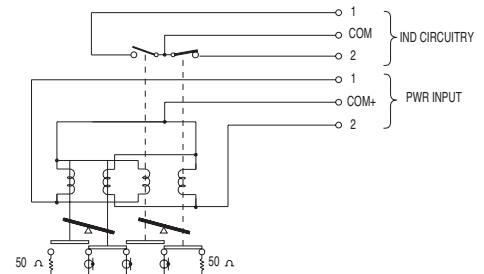
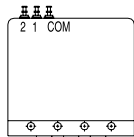
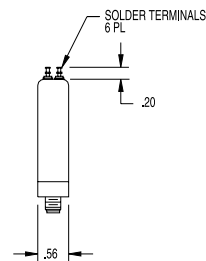
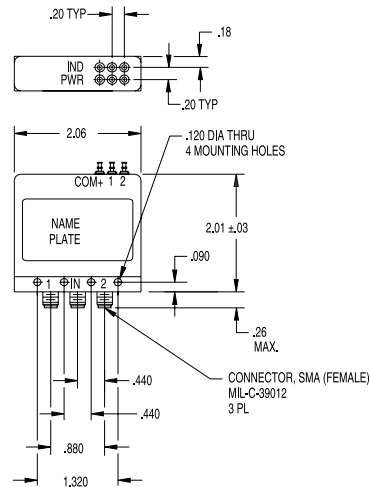

SCHEMATIC SHOWN WITH POSITION 1 CLOSED

SEM123LT

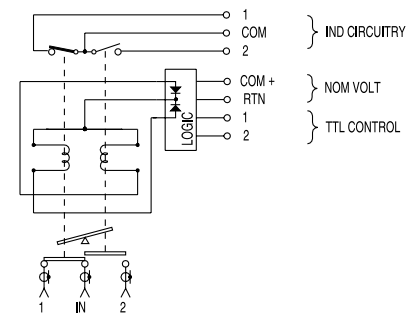
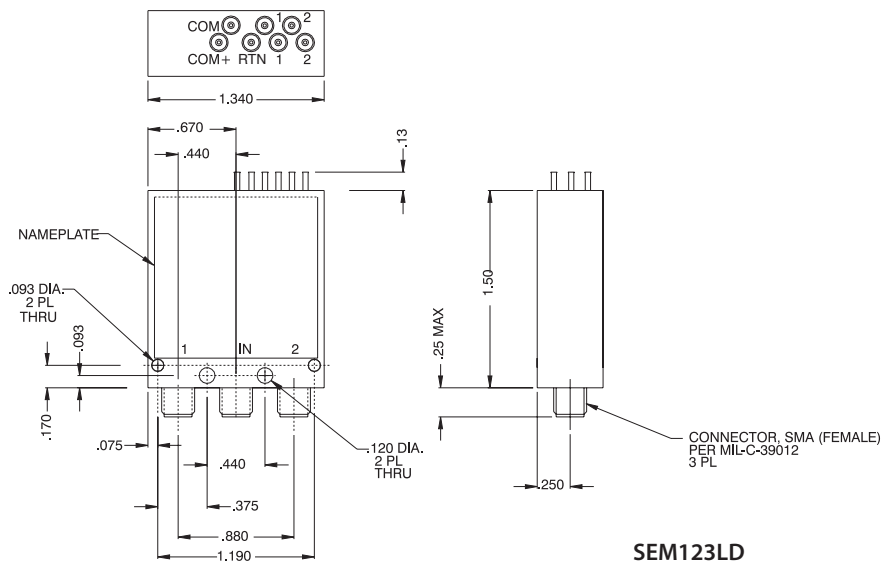

SCHEMATIC SHOWN WITH POSITION 1 CLOSED

SEM123LD

Stocked Electro-Mechanical Switches

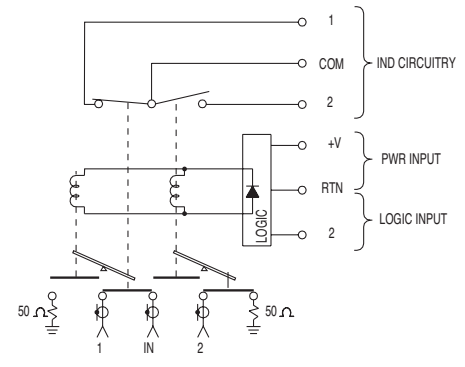
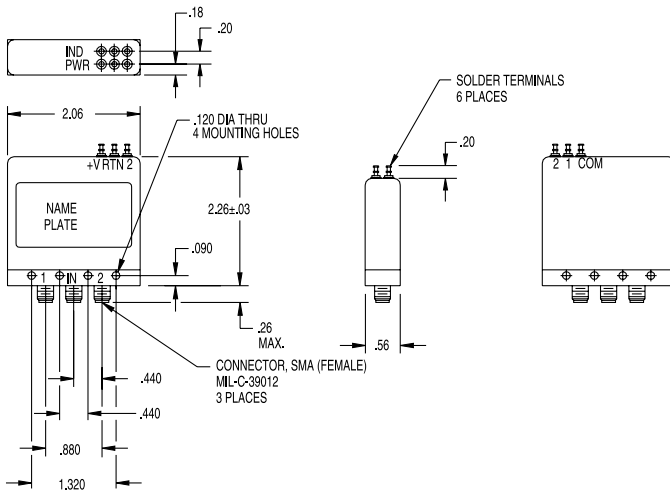

SCHEMATIC SHOWN IN FAILSAFE POSITION

SEM123DT

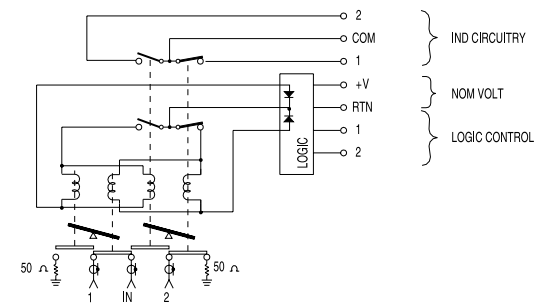
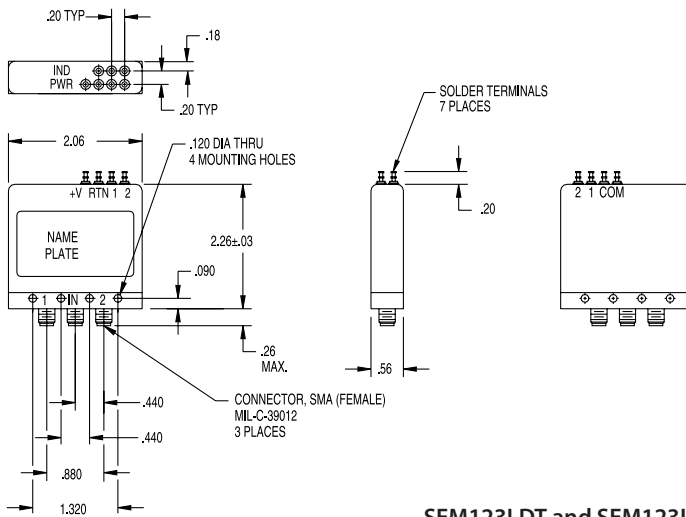

SCHEMATIC SHOWN WITH POSITION 1 CLOSED

SEM123LDT and SEM123LDT-24

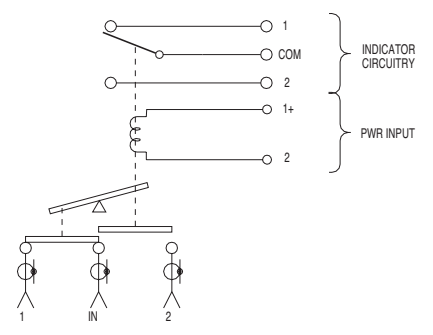
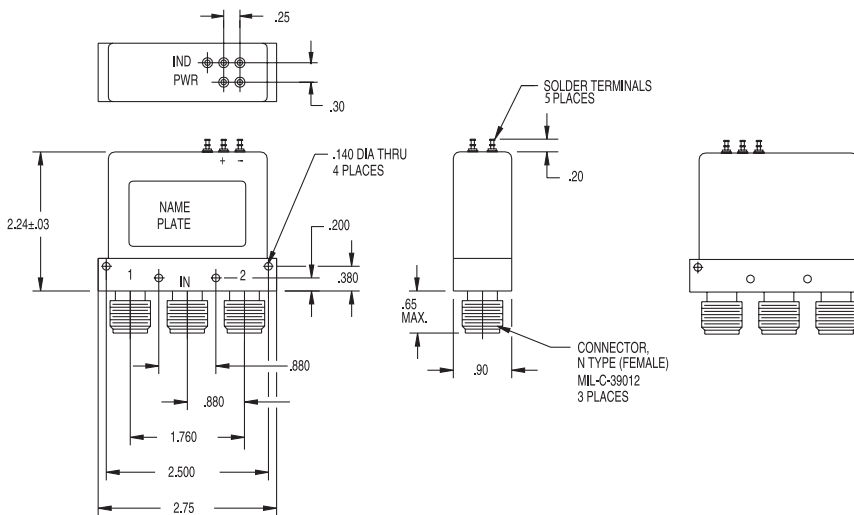

SCHEMATIC SHOWN IN FAILSAFE POSITION

SEM123N

Stocked Electro-Mechanical Switches

Outline Drawings and Schematics Dimensions in inches, unless otherwise specified.

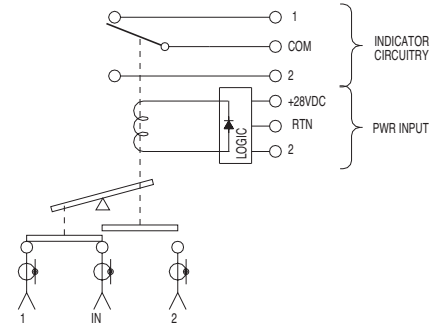
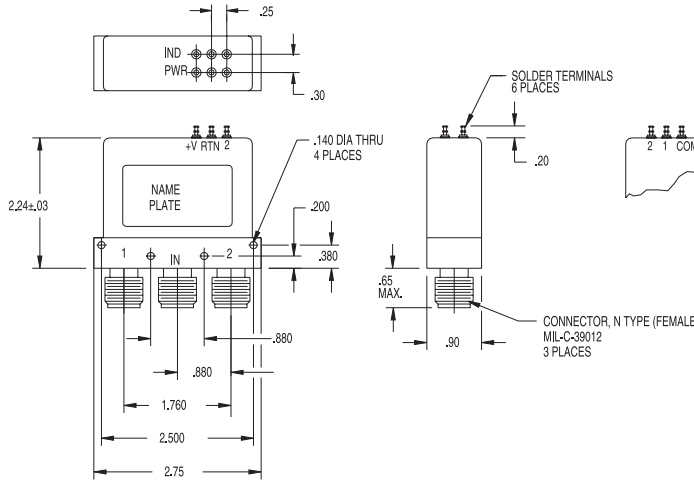

SCHEMATIC SHOWN IN FAILSAFE POSITION

SEM123DN

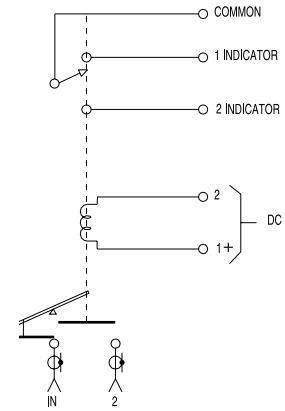
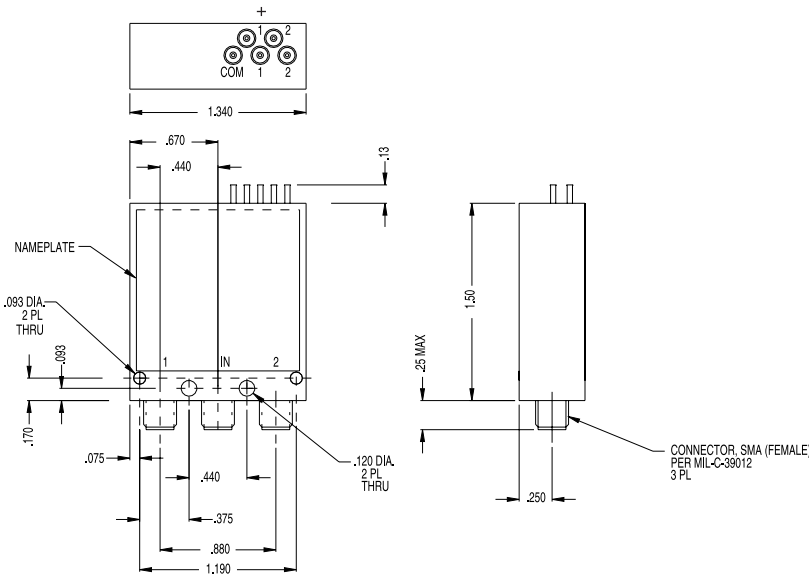

SCHEMATIC SHOWN IN FAILSAFE POSITION

SEM124

Stocked Electro-Mechanical Switches

Glossary

All switches are bi-directional. Inputs and Outputs are interchangeable.

SP2T – A single pole, double throw switch has one input port and two selectable output ports.

Multiposition Switch – A multiposition switch has one input port and more than two selectable output ports. Unlike some switches, Narda models can be switched directly to any one of the available output positions without sequencing through intervening positions.

Transfer Switch – A transfer switch has two independent paths that operate simultaneously in one of two selected positions.

Failsafe – The switch moves to the closed position when the actuating voltage is applied and always returns to a predetermined position when the voltage is removed.

Latching – Also called Pulse Latching, the switch remains in a preselected position whenever the actuating voltage is removed or interrupted and holds that preselected position until a voltage is applied to another position. This configuration must be pulse controlled with a pulse width of 20 ms to 100 ms duration. Standard polarity is common positive.

Normally Open – All output ports of the switch are disconnected from the input port until a voltage is applied to a selected position.

Terminated Units – Each unused or open output RF port is internally terminated in a 50-ohm resistive load (1W CW max.).

Common Specifications

RF Impedance.....	50 ohms nominal
Actuating Voltage.....	28 Vdc \pm 2 V
Switching Time.....	15 ms (max.)
Switching Sequence.....	Break Before Make
Operating Ambient Temp.....	-35°C to +70°C
Operating Life.....	1 million cycles/position
Designed to meet	MIL-S-3928

TTL – Selected position of the switch is controlled by a TTL Logic High. The switch requires only nominal +28 Vdc (additional 5 Vdc is not required).

TTL Logic Voltage Level:

Low 0 to 0.8 Vdc

High 2.5 to 5.0 Vdc

TTL Logic Input Current:

Low 0 mA

High 1.6 mA max. @ 3.85 Vdc

TTL Units – Transistor-Transistor-Logic circuitry enables the status of the switch to be controlled by the level of TTL logic input.

Suppression Diodes – Fast recovery silicon rectifiers (diodes) connected in parallel with the coils of the switch to suppress any transient voltage that may be generated by the coils.

Indicator Circuitry – A set of internally mounted contacts that allows external monitoring of switch RF status. Some switch series include a steering diode drive due to the electronic indicator.

Solder Terminal – A turret terminal is standard on all switches.

Self De-energizing Circuitry – With this option, a set of internally mounted contacts or electronically generated pulses disconnects the driver voltage as soon as RF contact has been made. This option is only available with latching type switches. Suppression diodes must be specified with this option.



Stocked Electro-Mechanical Switches

Power Handling Capability

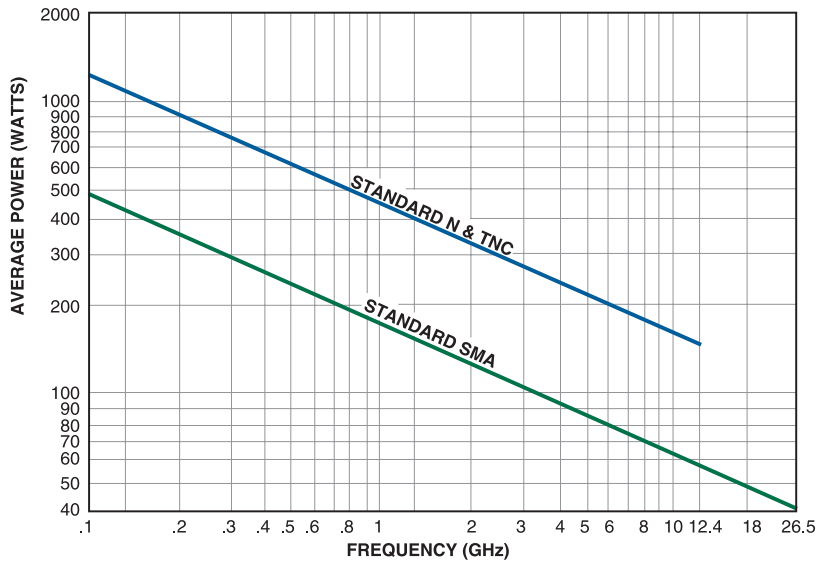

Power Handling Capability of Narda Switches vs. Frequency for Common RF Connectors
(for 25°C ambient temperature, matched 50ohm systems, sea level and cold switching)

For VSWR above 1.1, Derate Power Handling Capability as shown:

VSWR	Derating Factor
1.5	.94
2.0	.88
2.5	.83
3.0	.78
3.5	.73
4.0	.70

