

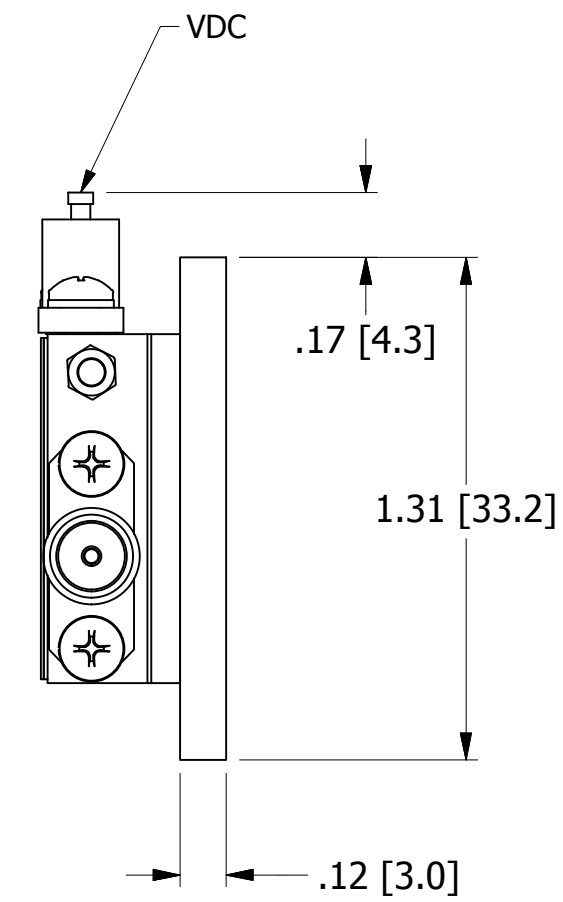

REVISIONS				
ZONE	LTR	DESCRIPTION	DATE	APPROVED
	1	PRELIMINARY RELEASE	11/19/2014	J.Bovard

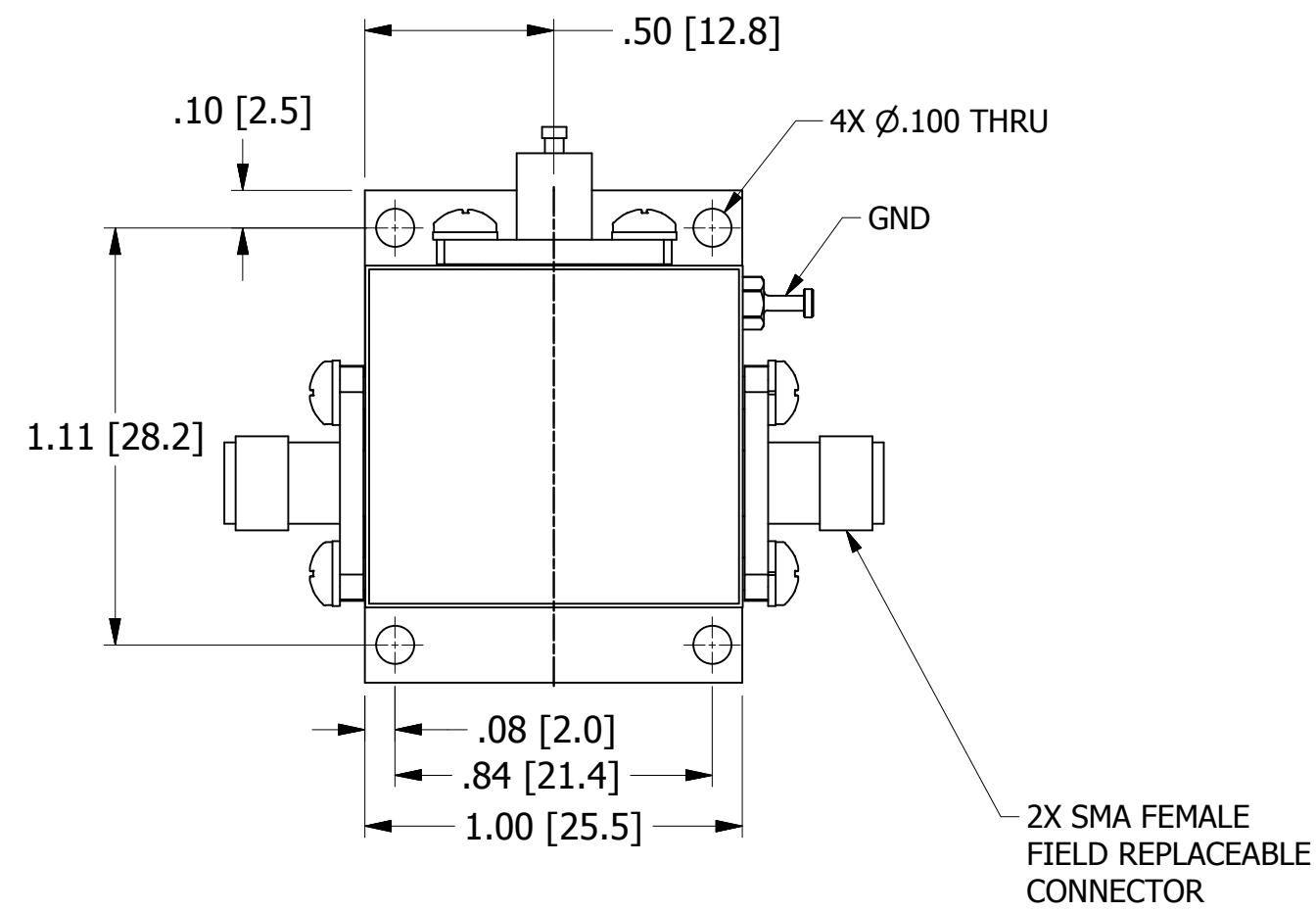
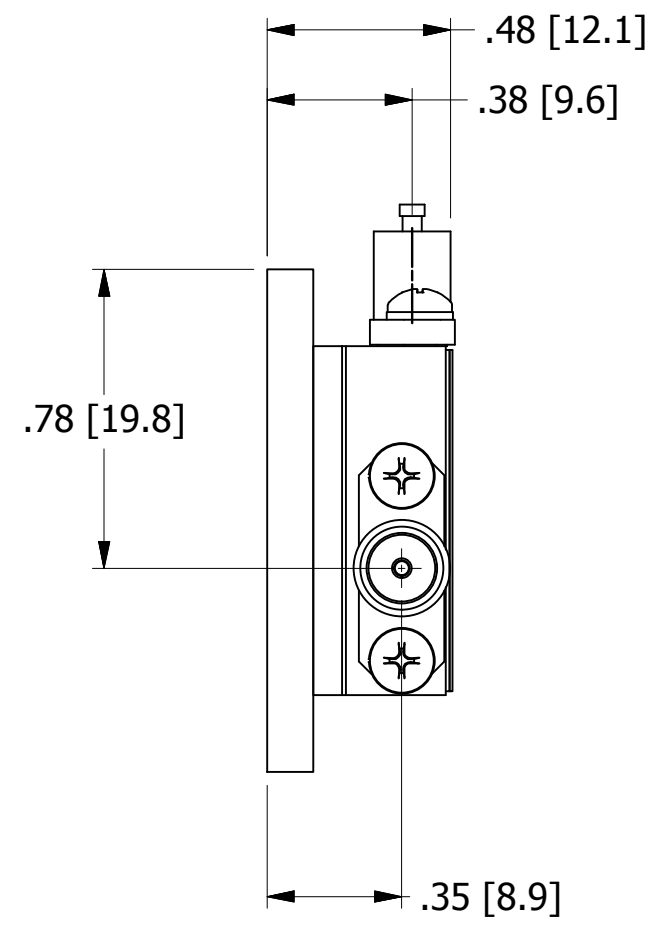
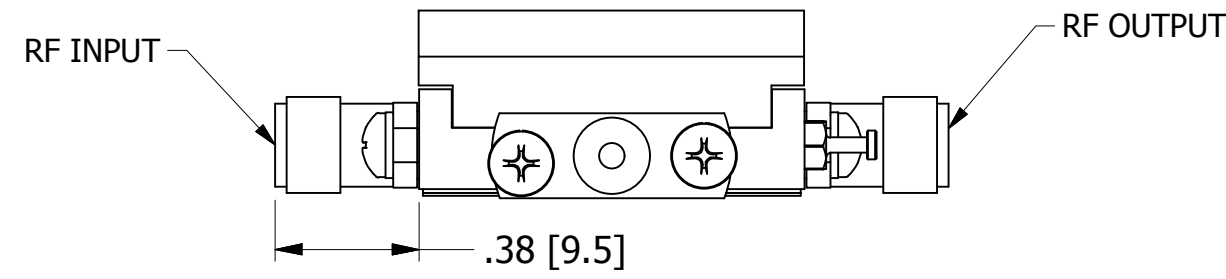
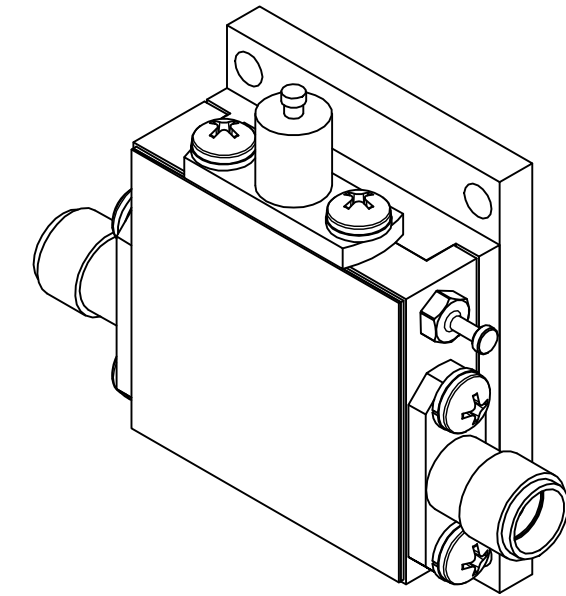
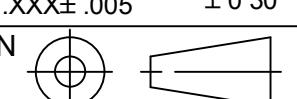

-5	-4	-3	-2	-1	NOMENCLATURE OR DESCRIPTION	SYM/NOTES	PART NO.	CODE IDENT.	ITEM NO.
					QTY REQ'D	PARTS LIST			
UNLESS OTHERWISE SPECIFIED DIMENSIONS ARE IN INCHES TOLERANCES ON						 100 Davids Drive, Hauppauge, New York 11788			
DECIMALS .XX± .01 ANGLES ± 0°30'									
PROJECTION 						APPROVED BY			
MATERIAL						DRN BY: J.Bovard NAME: DATE: 11/19/2014 CHKD BY: J.Bovard DATE: 11/20/2014			
FINISH						PROJ ENGR: _____ ENG SECT: _____ Q.A.: _____			
NEXT ASSY		USED ON		HEAT TREAT		SIZE C		CODE IDENT. NO. 33592	REV. 1
APPLICATION						SCALE		REF	SHEET 1 OF 1
						212903			