

| DASH NO. | APPLICATION | | REVISIONS | | | |
|----------|-------------|---------|-----------|-----------------|----------|-------------------|
| | NEXT ASSY | USED ON | LTR | DESCRIPTION | DATE | APPROVED |
| | | | A | Initial Release | 05/31/11 | <i>R. Scherer</i> |

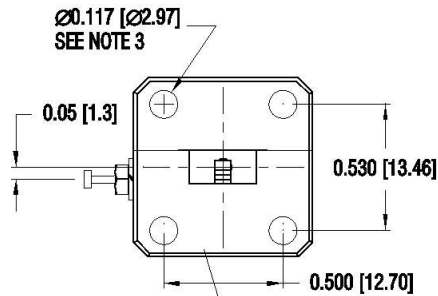

INPUT FLANGE CONFORMS TO WR28 SEE NOTE 3

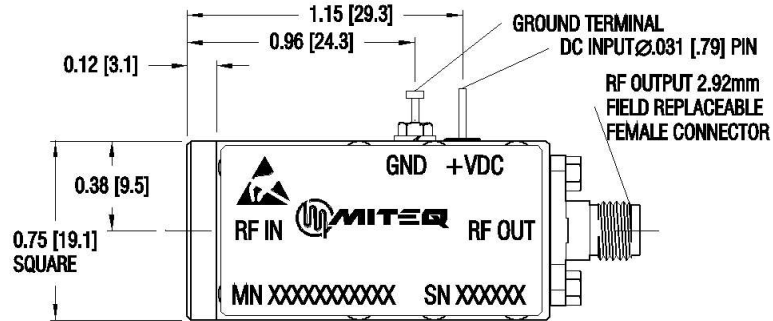
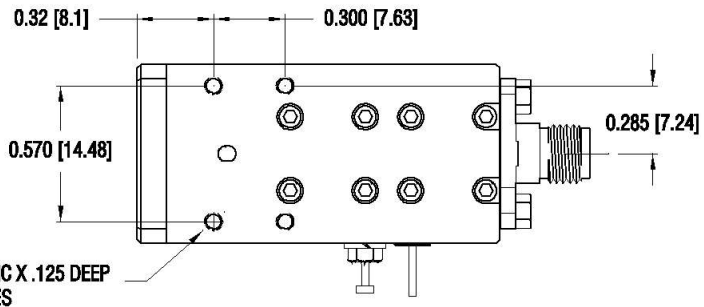
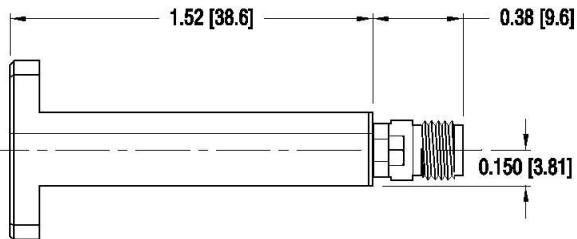

- NOTES:**
1. HOUSING, ALUMINUM ALLOY 6061 INTERNAL AMPLIFIERS HERMETICALLY SEALED KOVAR
 2. CONNECTORS STAINLESS STEEL, PASSIVATED
 3. FLANGE OPTIONS: HOLE TYPE, GASKET, AND CHOKE AVAILABLE. STANDARD SHOWN
 4. ESTIMATED WEIGHT 29 GRAMS
 5. DIMENSIONS IN BRACKETS ARE METRIC EQUIVALENT.

| | | | | | | |
|---------------------------------------------------------------------------------------------------|-------------------------------|----------|-------------------------------------------------|-----------------|-----------|-------|
| UNLESS OTHERWISE SPECIFIED DIMENSIONS ARE IN INCHES TOLERANCES ON | NAME | DATE | 100 Davids Drive, Hauppauge, New York 11788 | | | |
| | DWN <i>R. Scherer</i> | 11/15/10 | | | | |
| DECIMAL .X ±0.1 [2.5] DECIMAL .XX ±0.01 [0.25] DECIMAL .XXX ±0.005 [0.13] ANGLES X° ±30° | DFT DGN <i>R. Scherer</i> | 05/31/11 | WR28 IN - K OUT DUAL JS OUTLINE | | | |
| | PROJ ENGR <i>J. Buonaiuto</i> | 05/31/11 | | | | |
| ESD SENSITIVE COMPONENT | MFG ENGR | | SIZE | CODE IDENT. NO. | | REV |
| | Q.C. | | A | 33592 | 198012 | A |
| | CUST | | SCALE | PROJECT | MQ0179843 | SHEET |