

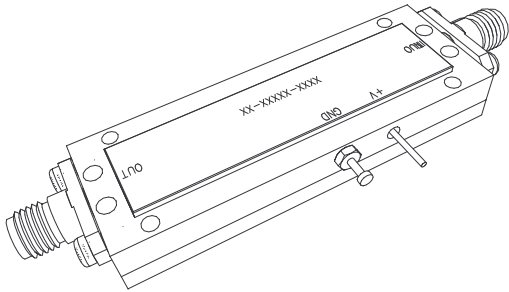

DASH NO.	APPLICATION		REVISIONS			
	NEXT ASSY	USED ON	LTR	DESCRIPTION	DATE	APPROVED
	HSG	169396	B	Incorporated ECN 3360	02/29/08	<i>EJMarty</i>
	PLT	109627-5				

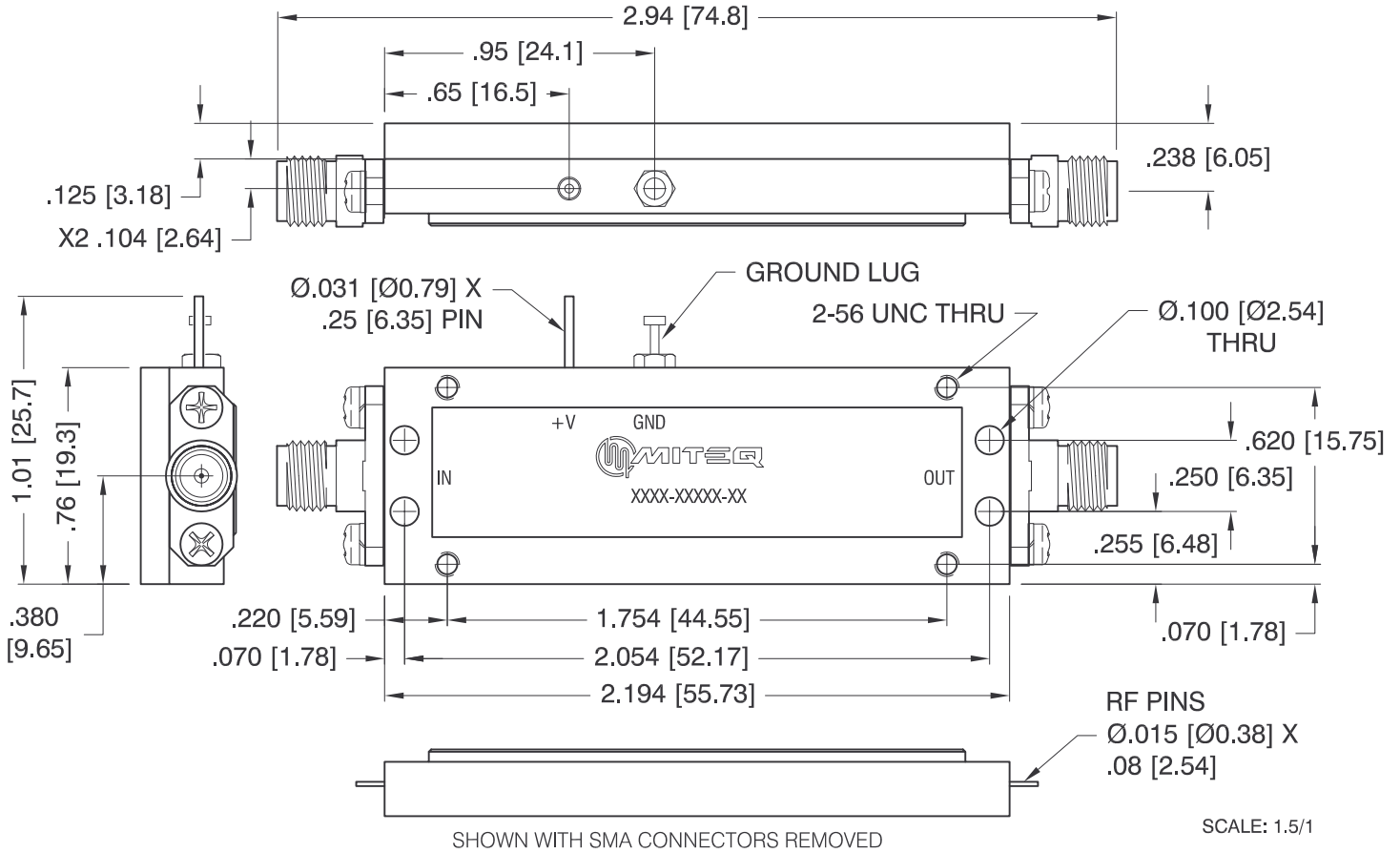

NOTES:

1. DIMENSIONS IN BRACKETS ARE IN MILLIMETER
2. ALL PINS Ø.015 [Ø0.38] X .080 [2.03] LONG
3. SHOWN WITH OPTIONAL FIELD REPLACEABLE SMA FEMALE CONNECTORS AND STANDARD BASE PLATE
4. HOUSING IS HERMETIC AND MADE OF KOVAR GOLD PLATED. SPACER PLATE ALUMINUM
5. FOR NON HERMETIC SEE OUTLINE 142958

UNLESS OTHERWISE SPECIFIED DIMENSIONS ARE IN INCHES TOLERANCES ON DECIMAL .X ±0.1 DECIMAL .XX ±0.01 DECIMAL .XXX ±0.005 ANGLES X° ±30'	NAME	DATE	 100 Davids Drive, Hauppauge, New York 11788			
	DWN BY <i>Ray S</i>	07/18/06				
	CHK BY <i>EJMarty</i>	05/18/09	HERMETIC 6 STAGE 4-12 GHz AMPLIFIER OUTLINE			
PROJ ENGR <i>N. Shaikh</i>	05/18/09					
SECT HEAD		SIZE A				
Q.C.		SCALE		PROJECT	SHEET 1 OF 1	
CUST						