

10 MHz - 15 GHz SCM FIBER OPTIC LINK

FEATURES

- Bandwidth..... 10 MHz to 15 GHz
- Small size
- No external control circuits required
- Transimpedance amplifier in both transmitter and receiver

APPLICATIONS

- Antenna remoting
- Local oscillator remoting
- Interfacility communication links

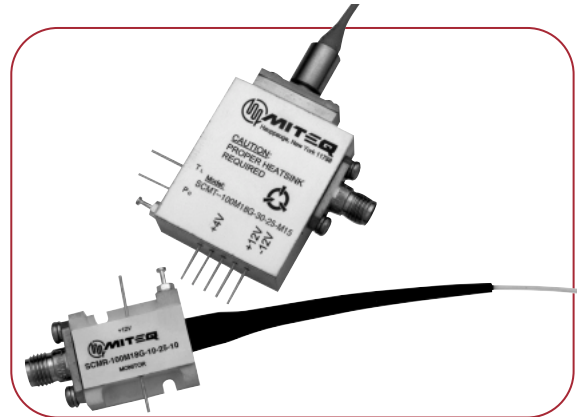

ELECTRICAL SPECIFICATIONS

PARAMETERS	CONDITION	UNITS	MIN.	TYP.	MAX.
Operating frequency (standard)*	±2 dB bandwidth		100 MHz		15 GHz
Gain		dB	10	18	25
Gain flatness		dB			±2
Noise figure		dB		19**	25
Group delay	Peak-to-peak (> 500 MHz)	ns		0.1	0.2
VSWR	Tx Input/Rx output				2:1
Phase noise	100 Hz offset	dBc	100		
Input power at 1 dB compression		dBm	-15		
Spurious-free dynamic range	At 15 GHz bandwidth	dB/Hz ^{2/3}		101	
Maximum input power	No damage	dBm			+10
RF connectors	SMA female (male optional)***				
Impedance	Input/output	Ohms		50	

NOTE: -30 dBm input power, 1m of fiber.

* Optional 10 MHz start frequency.

** At -15 GHz.

*** "K" style optional.

OPTICAL PERFORMANCE SPECIFICATIONS

PARAMETERS	CONDITION	UNITS	MIN.	TYP.	MAX.
Fiber optic connectors	FC/APC standard (other connector types optional)				
Fiber	Single mode fiber (9/125µm)				
Spectral width	FWHM	nm		0.06	
Optical power in fiber	Reference only	mW	3	5	9
Side mode suppression ratio		dB	30	40	

DC POWER REQUIREMENTS

PARAMETERS	CURRENT @ 25°C BASE PLATE	PIN #	MIN.	TYP.	MAX.
Transmitter	260 mA, 300 mA (max.)	4	+11V	+12V	+16V
	105 mA, 300 mA (max.)*	5	-11V	-12V	-16V
	100 mA @ 25°C, 1A (max.)	1	+3.5	+5	+6
Receiver	100 mA	2	+11V	+12V	+16V

* At low case temperatures, < 5°C, the laser cooler switches to heat mode and will exceed 105 mA typical current.



TYPICAL TEST DATA

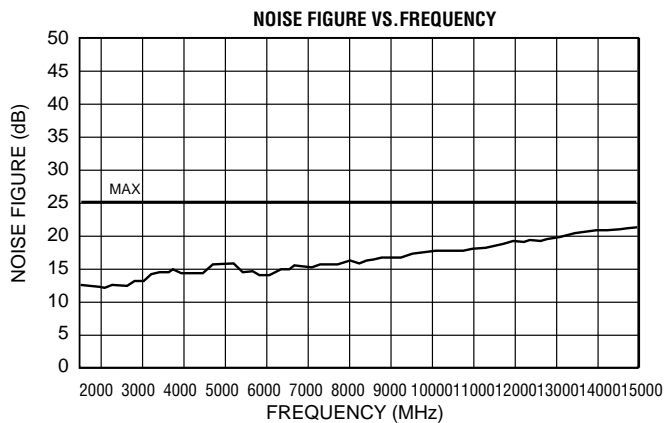
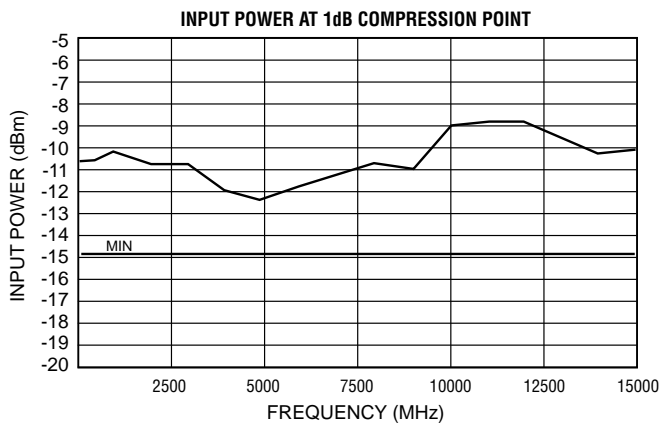
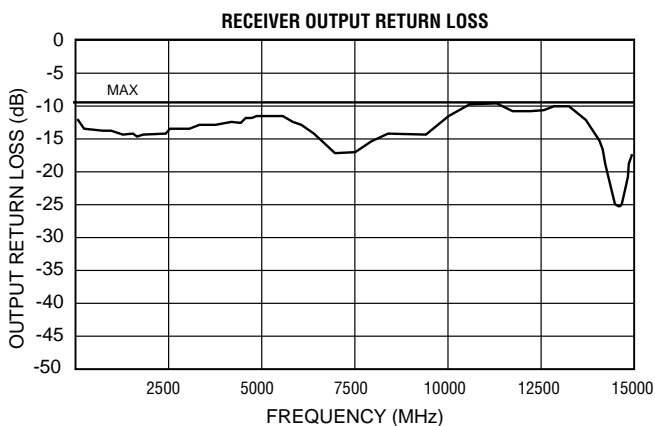
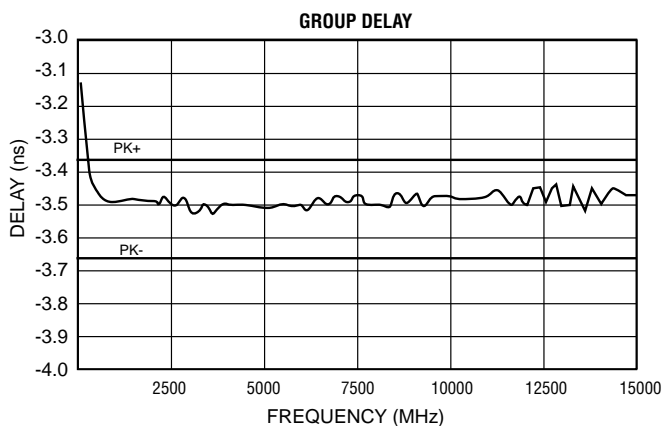
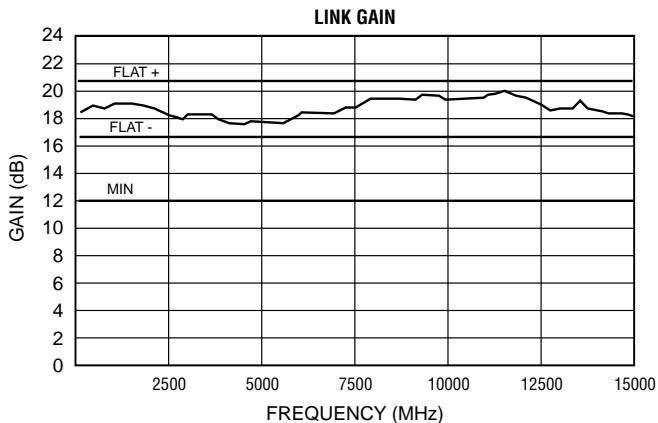
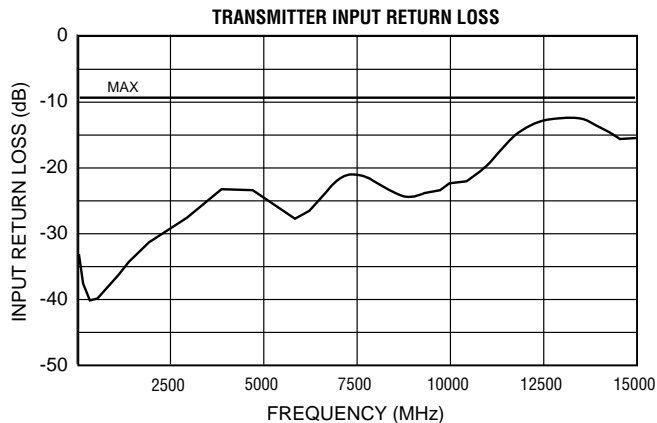

TYPICAL TEST DATA (CONT.)

**TRANSMITTER SPECTRUM
50 nM SPAN**

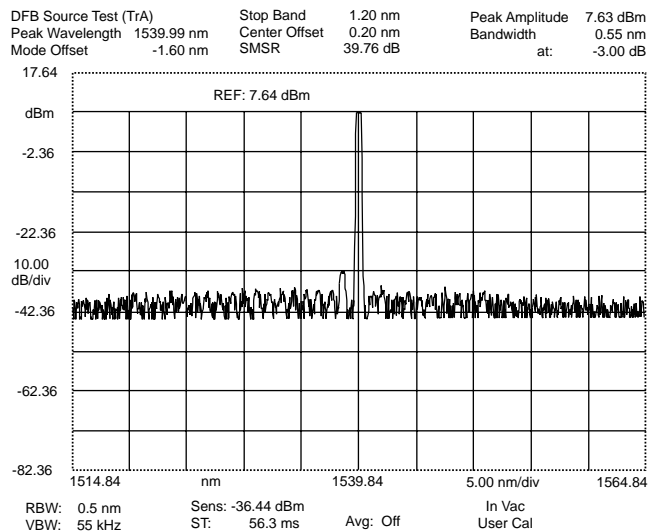

**TRANSMITTER SPECTRUM
5 nM SPAN**

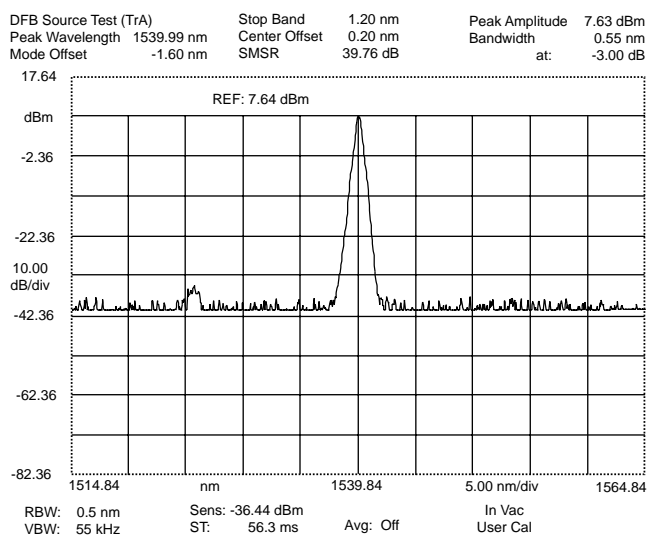

BLOCK DIAGRAM

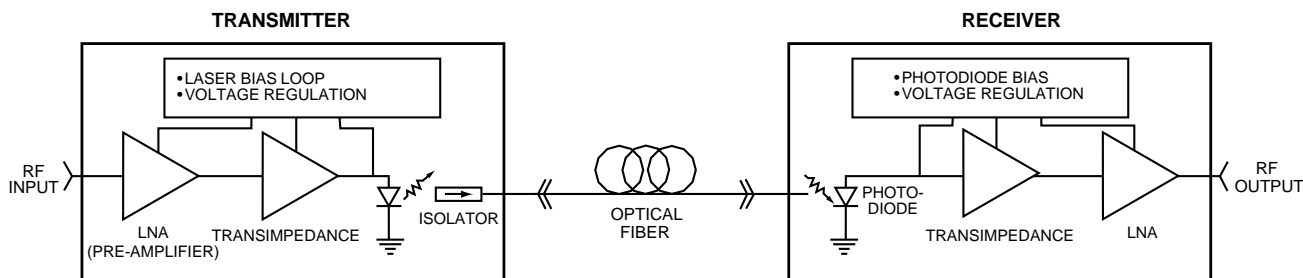

ORDERING INFORMATION

Transmitter Part number: SCMT-100M15G-30-25-M15
 Receiver Part number: SCMR-100M15G-10-25-10

Optional 10 MHz start frequency

Transmitter Part number: SCMT-10M15G-30-25-M15
 Receiver Part number: SCMR-10M15G-10-25-10

ENVIRONMENTAL CONDITIONS

Operating temperature -20 to +50°C
 Storage temperature -40 to +85°C
 Humidity 95% relative humidity, noncondensing
 Vibration 7.3 g's rms, 20-2000 CPS,
 Per MIL-STD-810B, Method 514,
 Procedure 5

NOTE: Link gain, noise figure and power compression can be tailored for specific applications. Please contact MITEQ.

TRANSMITTER OUTLINE DRAWING

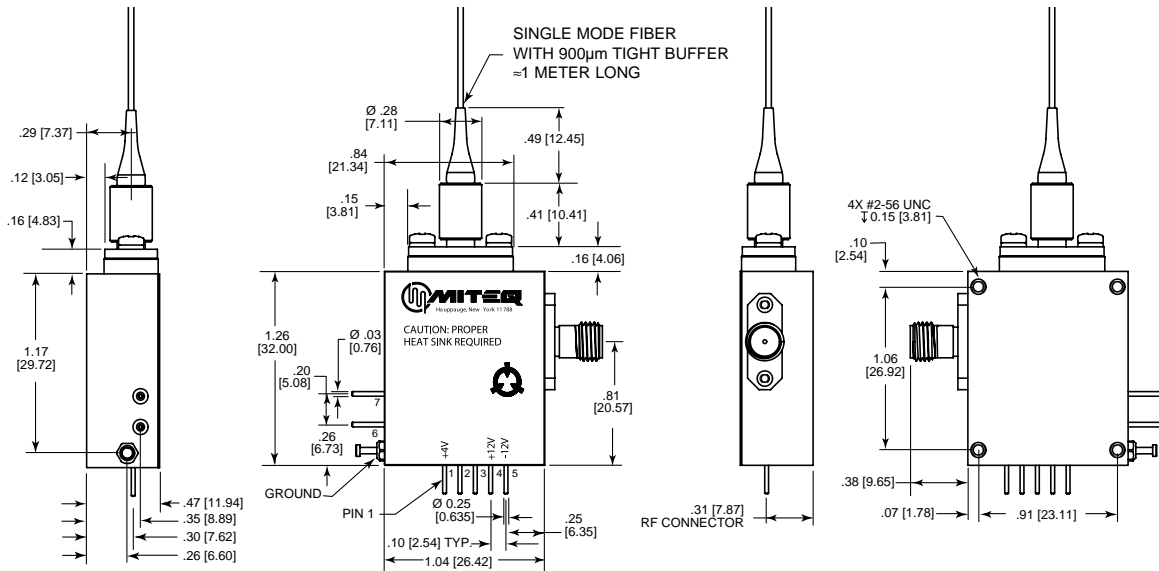

APPLY ALL VOLTAGES SIMULTANEOUSLY, OR IN THE FOLLOWING ORDER:

- +4V
- -12V
- +12V

TRANSMITTER POWER SUPPLY

PIN	VOLTAGE	CURRENT (AMPS)	NOTES
1	+4	0.325 1.2	@25°C BASE PLATE TEMP FOR MAXIMUM COOLING
2	N/C		
3	N/C		
4	+12	0.3	
5	-12	0.1 typ., 0.30 max.	

RF CONNECTOR: SMA STYLE (FEMALE STANDARD)
OPTICAL CONNECTOR: FC/APC STANDARD (OTHER STANDARDS AVAILABLE)
OPTICAL FIBER: 9/125 SINGLE MODE

TRANSMITTER OPERATIONAL STATUS

PIN	DESCRIPTION	NORMAL VOLTAGE	NOTES
6	OPTICAL POWER MONITOR	-2.5 V TO -1.5 V	0 VOLTS INDICATES NO LASER LIGHT
7	LASER TEMP MONITOR	-0.5 V TO +0.5 V	<-0.5 INDICATES HIGH LASER TEMP >+0.5 INDICATES LOW LASER TEMP

NOTE: ALLOW 2 MINUTES FOR LASER TEMP STABILIZATION AFTER APPLYING POWER.

RECEIVER OUTLINE DRAWING

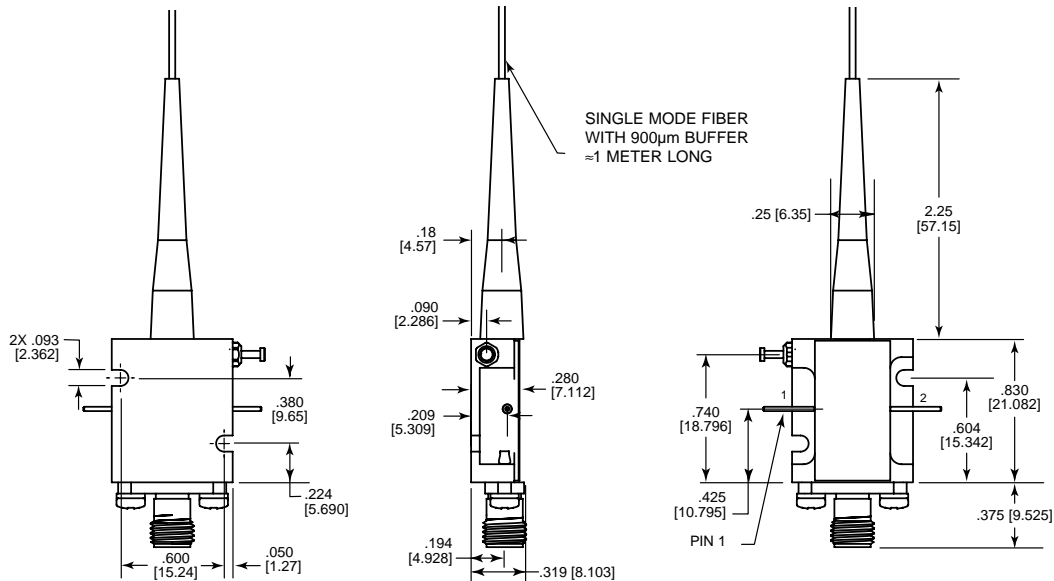

RECEIVER POWER SUPPLY

PIN	VOLTAGE	CURRENT (AMPS)	NOTES
1	PHOTOCURRENT MONITOR		REFER TO "OPERATIONAL STATUS"
2	+12	0.1	

RECEIVER OPERATIONAL STATUS

PIN	DESCRIPTION	NORMAL VOLTAGE	NOTES
1	OPTICAL CARRIER DETECT	> 1.0 UP TO +8	0 VOLTS INDICATES NO CARRIER PRESENT. VOLTAGE INCREASES APPROXIMATELY 1.3 V/mW WITH DETECTED OPTICAL POWER.

RF CONNECTOR: SMA (FEMALE STANDARD)
OPTICAL CONNECTOR: FC/APC STANDARD (OTHER STANDARDS AVAILABLE)
OPTICAL FIBER: 9/125 SINGLE MODE

NOTE: DIMENSIONS SHOWN IN BRACKETS [] ARE IN MILLIMETERS.

