

OCTAVE BAND

The following amplifiers are available as standard designs from MITEQ's JS Amplifier Department. However, it is important to note that the vast majority of applications require customized performance. We, at MITEQ, pride ourselves in supporting these custom engineering requirements. Our engineers are available to discuss not only the amplifier's performance, but the effects of integration of these amplifiers into your specific system.



JS2-01000200-045-10A

MODEL NUMBER	FREQUENCY RANGE (GHz)	GAIN (dB, Min.)	GAIN FLATNESS (±dB, Max.)	NOISE FIGURE (dB, Max.)	VSWR IN/OUT	OUTPUT PWR. @ 1 dB COMP. (dBm, Min.)	DC POWER @ +15 V (mA, Nom.)	OUTLINE DRAWING
JS2-00500100-045-10A	0.5-1	35	1	0.45	2:1	10	250	C
JS2-00500100-055-10A	0.5-1	35	1	0.55	2:1	10	250	C
JS2-00500100-075-10A	0.5-1	35	1	0.75	2:1	10	250	C
JS2-00500100-10-10A	0.5-1	35	1.2	1	2:1	10	250	C
JS2-01000200-045-10A	1-2	36	1	0.45	2:1	10	250	D
JS2-01000200-055-10A	1-2	36	1	0.55	2:1	10	250	D
JS2-01000200-075-10A	1-2	36	1	0.75	2:1	10	250	D
JS2-01000200-10-10A	1-2	36	1.2	1	2:1	10	250	D
JS2-02000400-045-10A	2-4	28	1.2	0.45	2:1	10	175	C
JS2-02000400-055-10A	2-4	28	1.2	0.55	2:1	10	175	C
JS2-02000400-065-10A	2-4	28	1.2	0.65	2:1	10	175	C
JS2-02000400-075-10A	2-4	28	1.2	0.75	2:1	10	175	C
JS2-02000400-10-10A	2-4	28	1.2	1	2:1	10	175	C
JS2-04000800-08-0A	4-8	22	1.2	0.8	2:1	0	150	A
JS2-04000800-09-5A	4-8	20	1.2	0.9	2:1	5	150	A
JS2-04000800-12-8A	4-8	20	1.2	1.2	2:1	8	150	A
JS2-04000800-15-8A	4-8	20	1.2	1.5	2:1	8	150	A
JS3-04000800-08-10A	4-8	30	1	0.8	2:1	10	175	D
JS3-04000800-10-10A	4-8	30	1	1	2:1	10	175	D
JS3-04000800-13-10A	4-8	30	1	1.3	2:1	10	175	D
JS3-04000800-15-10-10A	4-8	30	1	1.5	2:1	10	175	D
JS2-08001200-11-10A	8-12	15	1	1.1	2:1	10	150	A
JS2-08001200-15-10A	8-12	15	1.2	1.5	2:1	10	150	A
JS2-08001200-18-10A	8-12	15	1.2	1.8	2:1	10	150	A
JS3-08001200-11-10A	8-12	27	1	1.1	2:1	10	175	A
JS3-08001200-13-10A	8-12	27	1	1.3	2:1	10	175	A
JS3-08001200-15-10A	8-12	27	1	1.5	2:1	10	175	A
JS3-12001800-16-10A	12-18	23	1	1.6	2:1	10	175	A
JS3-12001800-20-10A	12-18	23	1	2	2:1	10	175	A
JS3-12001800-25-10A	12-18	23	1	2.5	2:1	10	175	A
JS3-12001800-30-10A	12-18	23	1	3	2:1	10	175	A
JS4-12001800-12-5A	12-18	33	1	1.2	2:1	5	200	A
JS4-12001800-13-5A	12-18	33	1	1.3	2:1	5	200	A
JS4-12001800-155-10A	12-18	33	1	1.55	2:1	10	200	A
JS4-12001800-18-10A	12-18	33	1	1.8	2:1	10	200	A
JS4-12001800-30-18-10A	12-18	33	1	3	2:1	10	200	A

NOTES: Most octave band amplifiers are available with waveguide input and output interfaces (see Figure E, page 38). Available waveguide sizes range from WR19 to WR137.

OCTAVE BAND (CONT.)

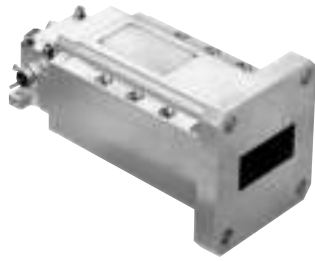

JSW4-08001200-12-0A

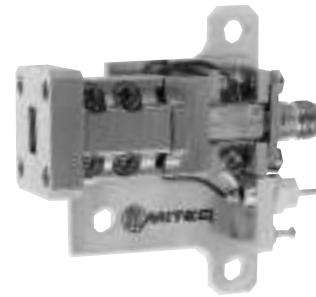

JSW4-26004000-30-8A

MODEL NUMBER	FREQUENCY RANGE (GHz)	GAIN (dB, Min.)	GAIN FLATNESS (±dB, Max.)	NOISE FIGURE (dB, Max.)	VSWR IN/OUT	OUTPUT PWR. @ 1 dB COMP. (dBm, Min.)	DC POWER @ +15 V (mA, Nom.)	OUTLINE DRAWING
JS2-18002600-20-5A	18–26	14	1	2	2:1	5	100	A
JS2-18002600-25-5A	18–26	14	1	2.5	2:1	5	100	A
JS2-18002600-30-5A	18–26	14	1	3	2:1	5	100	A
JS3-18002600-21-8A	18–26	24	1	2.1	2:1	8	175	A
JS3-18002600-25-8A	18–26	24	1	2.5	2:1	8	175	A
JS3-18002600-30-8A	18–26	24	1	3	2:1	8	175	A
JS4-18002600-18-8A	18–26	35	1	1.8	2:1	8	200	A
JS4-18002600-21-8A	18–26	35	1	2.1	2:1	8	200	A
JS4-18002600-26-10A	18–26	35	1	2.6	2:1	10	200	A
JS2-26004000-35-5A	26–40	10	2	3.5	2.5:1	5	100	A
JS2-26004000-40-5A	26–40	10	2	4	2.5:1	5	100	A
JS2-26004000-45-5A	26–40	10	2	4.5	2.5:1	5	100	A
JS2-26004000-100-20A	26–40	10	2.5	10	2.5:1	20	600,100 ⁽¹⁾	A
JS3-26004000-35-5A	26–40	18	2.5	3.5	2.5:1	8	175	A
JS3-26004000-40-5A	26–40	18	2.5	4	2.5:1	8	175	A
JS3-26004000-45-5A	26–40	18	2.5	4.5	2.5:1	8	175	A
JS4-26004000-27-8A	26–40	26	2.5	2.7	2:1	8	200	A
JS4-26004000-30-8A	26–40	25	2.5	3	2:1	8	200	A
JS4-26004000-35-8A	26–40	23	2.5	3.5	2:1	8	200	A
JS4-26004000-40-8A	26–40	23	2.5	4	2:1	8	200	A
JS4-40006000-60-0P	40–60	15	1.5	6	2.75:1	0	175	A
JS4-40006000-65-0P	40–60	15	1.5	6.5	2.75:1	0	175	A
JS4-40006000-70-0A	40–60	15	1.5	7	2.75:1	0	175	A
JS4-40006000-75-0A	40–60	15	1.5	7.5	2.75:1	0	175	A
JS4-40006000-80-0P	40–60	15	1.5	8.5	2.75:1	0	175	A

NOTES: Most octave band amplifiers are available with waveguide input and output interfaces (see Figure E, page 38). Available waveguide sizes range from WR19 to WR137.

⁽¹⁾ Requires ±8 VDC.

MULTIOCTAVE BAND



JS4-26004000-25-5A

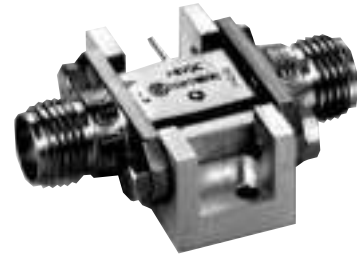

JS4-18004000-30-5A

MODEL NUMBER	FREQUENCY RANGE (GHz)	GAIN (dB, Min.)	GAIN FLATNESS (±dB, Max.)	NOISE FIGURE (dB, Max.)	VSWR IN/OUT	OUTPUT PWR. @ 1 dB COMP. (dBm, Min.)	DC POWER @ +15 V (mA, Nom.)	OUTLINE DRAWING
JS2-00500200-05-10A	0.5-2	32	1	0.5	2:1	10	250	C
JS2-00500200-07-10A	0.5-2	32	1	0.7	2:1	10	295	C
JS2-00500200-08-10A	0.5-2	32	1	0.8	2:1	10	295	C
JS2-00500200-10-10A	0.5-2	32	1	1	2:1	10	295	C
JS2-00500200-15-10A	0.5-2	32	1	1.5	2:1	10	295	C
JS2-01000400-08-10A	1-4	27	1	0.8	2:1	10	200	C
JS2-01000400-09-10A	1-4	27	1	0.9	2:1	10	200	C
JS2-01000400-11-10A	1-4	27	1	1.1	2:1	10	200	C
JS2-01000400-20-10A	1-4	27	1	2	2:1	10	200	C
JS2-02000600-08-0A	2-6	22	1	0.8	2:1	0	125	A
JS2-02000600-09-0A	2-6	22	1	0.9	2:1	0	125	A
JS2-02000600-12-10A	2-6	20	1.5	1.2	2:1	10	175	A
JS2-02000600-20-10A	2-6	20	1.5	2	2:1	10	175	A
JS2-02000800-08-0A	2-8	22	1.25	0.8	2:1	0	125	A
JS2-02000800-10-0A	2-8	20	1.25	1	2:1	0	125	A
JS2-02000800-12-10A	2-8	18	1.25	1.2	2:1	10	175	A
JS2-02000800-20-10A	2-8	18	1.25	2	2:1	10	175	A
JS3-02001800-23-5A	2-18	23	1.8	2.3	2.5:1	5	150	A
JS3-02001800-25-5A	2-18	23	1.8	2.5	2.5:1	5	150	A
JS3-02001800-30-5A	2-18	23	1.8	3	2.5:1	5	150	A
JS3-02001800-35-5A	2-18	23	1.8	3.5	2.5:1	5	150	A
JS3-02001800-50-5A	2-18	23	1.8	5	2.5:1	5	150	A
JS4-02001800-22-5A	2-18	30	2	2.2	2.5:1	5	200	B
JS4-02001800-24-5A	2-18	30	2	2.4	2.5:1	5	200	A
JS4-02001800-27-5A	2-18	30	2	2.7	2.5:1	5	200	A
JS4-02001800-32-5A	2-18	30	2	3.2	2.5:1	5	200	A
JS4-02001800-50-5A	2-18	30	2	5	2.5:1	5	200	A
JS3-02002600-33-5A	2-26	21	2.5	3.3	2.5:1	5	150	A
JS3-02002600-35-5A	2-26	21	2.5	3.5	2.5:1	5	150	A
JS3-02002600-40-5A	2-26	21	2.5	4	2.5:1	5	150	A
JS3-06001800-16-10A	6-18	26	1.8	1.6	2:1	10	175	A
JS3-06001800-21-10A	6-18	26	1.8	2.1	2:1	10	175	A
JS3-06001800-25-10A	6-18	26	1.8	2.5	2:1	10	175	A
JS3-06001800-30-10A	6-18	26	1.8	3	2:1	10	175	A
JS4-06001800-145-10A	6-18	34	2	1.45	2:1	10	200	A
JS4-06001800-16-10A	6-18	34	2	1.6	2:1	10	200	A
JS4-06001800-20-10A	6-18	34	2	2	2:1	10	200	A
JS4-06001800-25-10A	6-18	34	2	2.5	2:1	10	200	A
JS4-06001800-30-10A	6-18	34	2	3	2:1	10	200	A

MULTIOCTAVE BAND (CONT.)

MODEL NUMBER	FREQUENCY RANGE (GHz)	GAIN (dB, Min.)	GAIN FLATNESS (\pm dB, Max.)	NOISE FIGURE (dB, Max.)	VSWR IN/OUT	OUTPUT PWR. @ 1 dB COMP. (dBm, Min.)	DC POWER @ +15 V (mA, Nom.)	OUTLINE DRAWING
JS3-08001800-16-5A	8–18	24	1.5	1.6	2:1	5	150	A
JS3-08001800-20-5A	8–18	24	1.5	2	2:1	5	150	A
JS3-08001800-25-10A	8–18	24	1.5	2.5	2:1	10	150	A
JS3-08001800-30-10A	8–18	24	1.5	3	2:1	10	150	A
JS4-08001800-145-5A	8–18	32	2	1.45	2:1	5	200	A
JS4-08001800-17-5A	8–18	32	2	1.7	2:1	5	200	A
JS4-08001800-20-10A	8–18	32	2	2	2:1	10	200	A
JS4-08001800-25-10A	8–18	32	2	2.5	2:1	10	200	A
JS4-08001800-30-10A	8–18	32	2	3	2:1	10	200	A
JS3-12002600-25-8A	12–26	24	2.5	2.5	2.2:1	8	150	A
JS3-12002600-30-8A	12–26	24	2.5	3	2.2:1	8	150	A
JS3-12002600-35-8A	12–26	24	2.5	3.5	2.2:1	8	150	A
JS4-12002600-22-8A	12–26	33	2.2	2.2	2:1	8	200	A
JS4-12002600-30-8A	12–26	33	2.2	3	2:1	8	200	A
JS4-12002600-35-8A	12–26	33	2.2	3.5	2:1	8	200	A
JS3-18004000-38-8A	18–40	16	2.5	3.8	2.5:1	8	150	A
JS3-18004000-42-8A	18–40	16	2.5	4.2	2.5:1	8	150	A
JS3-18004000-50-8A	18–40	16	2.5	5	2.5:1	8	150	A
JS4-18004000-30-5A	18–40	23	2.5	3	2.5:1	5	200	A
JS4-18004000-33-5A	18–40	23	2.5	3.3	2.5:1	5	200	A
JS4-18004000-35-8A	18–40	23	2.5	3.5	2.5:1	8	200	A
JS4-18004000-40-8A	18–40	23	2.5	4	2.5:1	8	200	A
JS4-18004000-50-8A	18–40	23	2.5	5	2.5:1	8	200	A

ULTRA-WIDEBAND

MODEL NUMBER	FREQUENCY RANGE (GHz)	GAIN (dB, Min.)	GAIN FLATNESS (±dB, Max.)	NOISE FIGURE (dB, Max.)	VSWR IN/OUT	OUTPUT PWR. @ 1 dB COMP. (dBm, Min.)	DC POWER @ +15 V (mA, Nom.)	OUTLINE DRAWING
JS2-00100200-07-10A	0.1–2	36	1	0.7 ⁽²⁾	2:1	10	325	D
JS2-00100200-09-10A	0.1–2	36	1	0.9 ⁽²⁾	2:1	10	325	D
JS2-00100200-11-10A	0.1–2	36	1	1.1 ⁽²⁾	2:1	10	325	D
JS2-00100200-15-10A	0.1–2	36	1	1.5 ⁽²⁾	2:1	10	325	D
JS2-00100400-08-10A	0.1–4	27	1	0.8 ⁽²⁾	2:1	10	200	C
JS2-00100400-10-10A	0.1–4	27	1	1 ⁽²⁾	2:1	10	200	C
JS2-00100400-12-10A	0.1–4	27	1	1.2 ⁽²⁾	2:1	10	200	C
JS2-00100600-10-3A	0.1–6	23	1.5	1 ⁽³⁾	2:1	3	175	A
JS2-00100600-12-3A	0.1–6	23	1.5	1.2 ⁽³⁾	2:1	3	175	A
JS2-00100600-14-8A	0.1–6	21	1.5	1.4 ⁽³⁾	2:1	8	175	A
JS2-00100600-20-8A	0.1–6	21	1.5	2 ⁽³⁾	2:1	8	175	A
JS2-00100800-13-0A	0.1–8	20	1.5	1.3 ⁽³⁾	2:1	0	175	A
JS2-00100800-15-0A	0.1–8	20	1.5	1.5 ⁽³⁾	2:1	0	175	A
JS2-00100800-17-8A	0.1–8	20	1.5	1.7 ⁽³⁾	2:1	8	175	A
JS2-00100800-25-8A	0.1–8	20	1.5	2.5 ⁽³⁾	2:1	8	175	A
JS3-00101000-20-5A	0.1–10	23	1.5	2 ⁽⁴⁾	2.5:1/2.2:1	5	150	B
JS3-00101000-22-5A	0.1–10	23	1.5	2.2 ⁽⁴⁾	2.5:1/2.2:1	5	150	A
JS3-00101000-25-5A	0.1–10	23	1.5	2.5 ⁽⁴⁾	2.5:1/2.2:1	5	150	A
JS3-00101000-35-5A	0.1–10	23	1.5	3.5 ⁽⁴⁾	2.5:1/2.2:1	5	150	A
JS3-00101200-21-5A	0.1–12	23	1.5	2.1 ⁽⁴⁾	2.5:1/2.2:1	5	150	B
JS3-00101200-23-5A	0.1–12	23	1.5	2.3 ⁽⁴⁾	2.5:1/2.2:1	5	150	A
JS3-00101200-27-5A	0.1–12	23	1.5	2.7 ⁽⁴⁾	2.5:1/2.2:1	5	150	A
JS3-00101200-35-5A	0.1–12	23	1.5	3.5 ⁽⁴⁾	2.5:1/2.2:1	5	150	A
JS3-00101800-24-5A	0.1–18	23	1.8	2.4 ⁽⁴⁾	2.5:1/2.2:1	5	150	B
JS3-00101800-33-5A	0.1–18	23	1.8	3.3 ⁽⁴⁾	2.5:1/2.2:1	5	150	A
JS3-00101800-40-5A	0.1–18	23	1.8	4 ⁽⁴⁾	2.5:1/2.2:1	5	150	A
JS4-00101800-23-5A	0.1–18	29	1.8	2.3 ⁽⁴⁾	2.5:1/2.2:1	5	200	B
JS4-00101800-28-5A	0.1–18	29	1.8	2.8 ⁽⁴⁾	2.5:1/2.2:1	5	200	A
JS4-00101800-33-5A	0.1–18	29	1.8	3.3 ⁽⁴⁾	2.5:1/2.2:1	5	200	A
JS4-00101800-40-5A	0.1–18	29	1.8	4 ⁽⁴⁾	2.5:1/2.2:1	5	200	A
JS4-00102000-25-5A	0.1–20	28	1.8	2.5 ⁽⁴⁾	2.5:1	5	200	B
JS4-00102000-30-5A	0.1–20	28	1.8	3 ⁽⁴⁾	2.5:1	5	200	A
JS4-00102000-35-5A	0.1–20	28	1.8	3.5 ⁽⁴⁾	2.5:1	5	200	A
JS3-00102600-33-5A	0.1–26	20	2.5	3.3 ⁽⁴⁾	2.5:1	5	150	A
JS3-00102600-37-5A	0.1–26	20	2.5	3.7 ⁽⁴⁾	2.5:1	5	150	A
JS3-00102600-42-5A	0.1–26	20	2.5	4.2 ⁽⁴⁾	2.5:1	5	150	A
JS4-00102600-28-5A	0.1–26	27	2.5	2.8 ⁽⁴⁾	2.5:1	5	200	B
JS4-00102600-30-5A	0.1–26	27	2.5	3 ⁽⁴⁾	2.5:1	5	200	B
JS4-00102600-32-5A	0.1–26	27	2.5	3.2 ⁽⁴⁾	2.5:1	5	200	B
JS4-00102600-35-5A	0.1–26	27	2.5	3.5 ⁽⁴⁾	2.5:1	5	200	A
JS4-00102600-50-5A	0.1–26	27	2.5	5 ⁽⁴⁾	2.5:1	5	200	A
JS4-00104000-65-5A	0.1–40	14	4.5	6.5 ⁽⁴⁾	2.75:1	5	200	B
JS4-00104000-75-5A	0.1–40	14	4.5	7.5 ⁽⁴⁾	2.75:1	5	200	B
JS4-00104000-85-5A	0.1–40	14	4.5	8.5 ⁽⁴⁾	2.75:1	5	200	B

NOTES: (2) Noise figure is higher below 250 MHz.
(3) Noise figure is higher below 500 MHz.
(4) Noise figure is higher below 800 MHz.

OUTLINE DRAWINGS

FIGURE A (JSD PACKAGE)

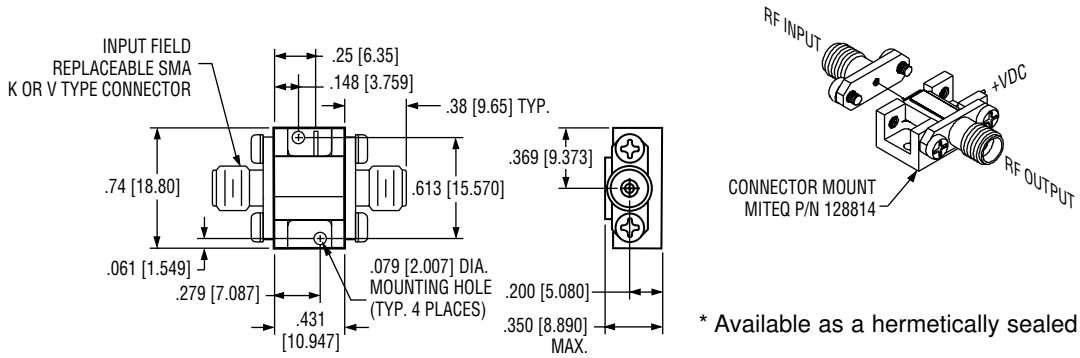

FIGURE B (JS4 PACKAGE)

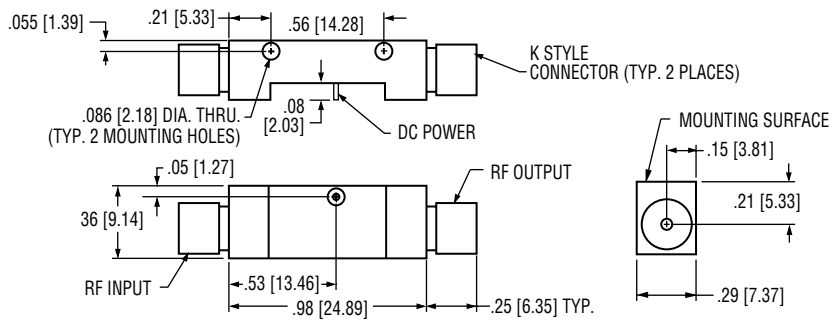
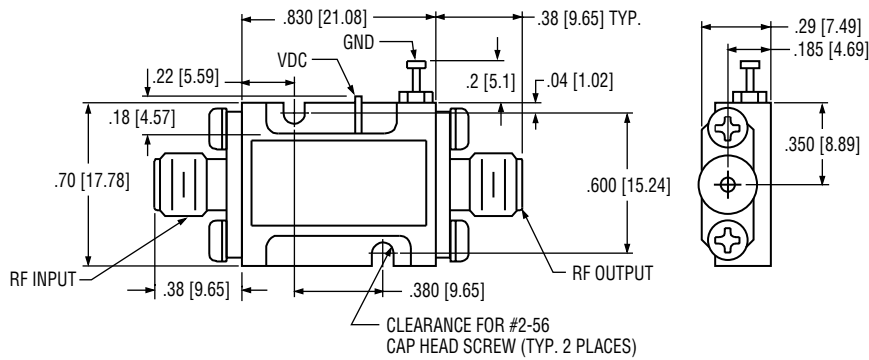

FIGURE C (JSS PACKAGE)



* Available as a hermetically sealed package

NOTE: DIMENSIONS SHOWN IN BRACKETS [] ARE IN MILLIMETERS.

OUTLINE DRAWINGS (CONT.)

**FIGURE D
(JSM PACKAGE)**

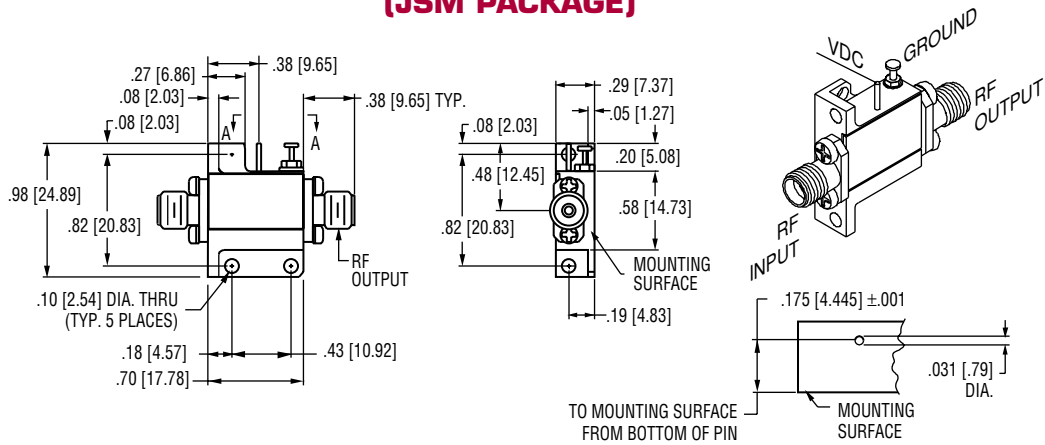

**FIGURE E
(TYPICAL AMPLIFIER WITH WR19 WAVEGUIDE INTERFACE)**

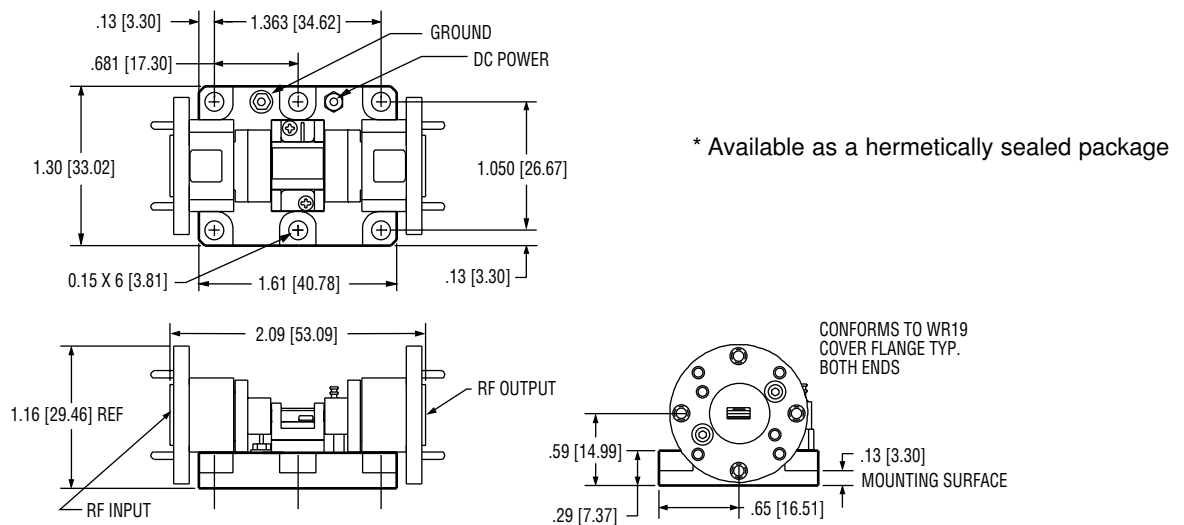

**FIGURE F
(JSH4 PACKAGE)**

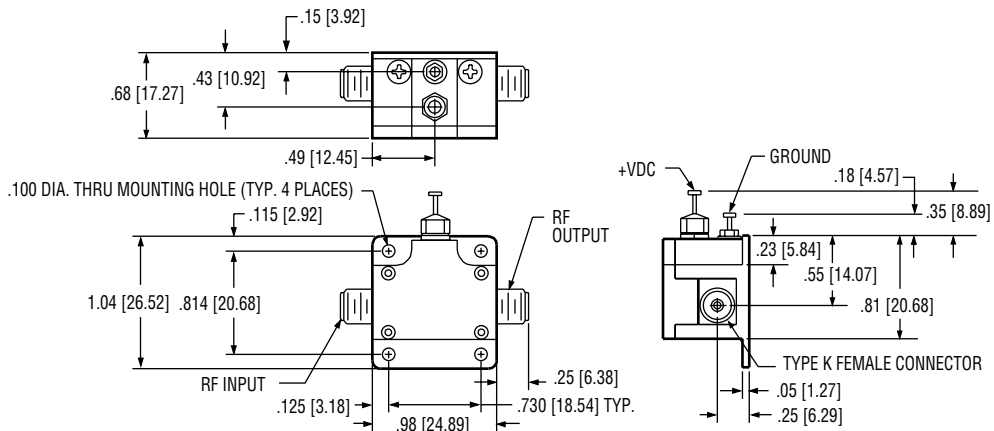

NOTE: DIMENSIONS SHOWN IN BRACKETS [] ARE IN MILLIMETERS.

OUTLINE DRAWINGS (CONT.)

WRD180 (INPUT AND OUTPUT INTERFACE)

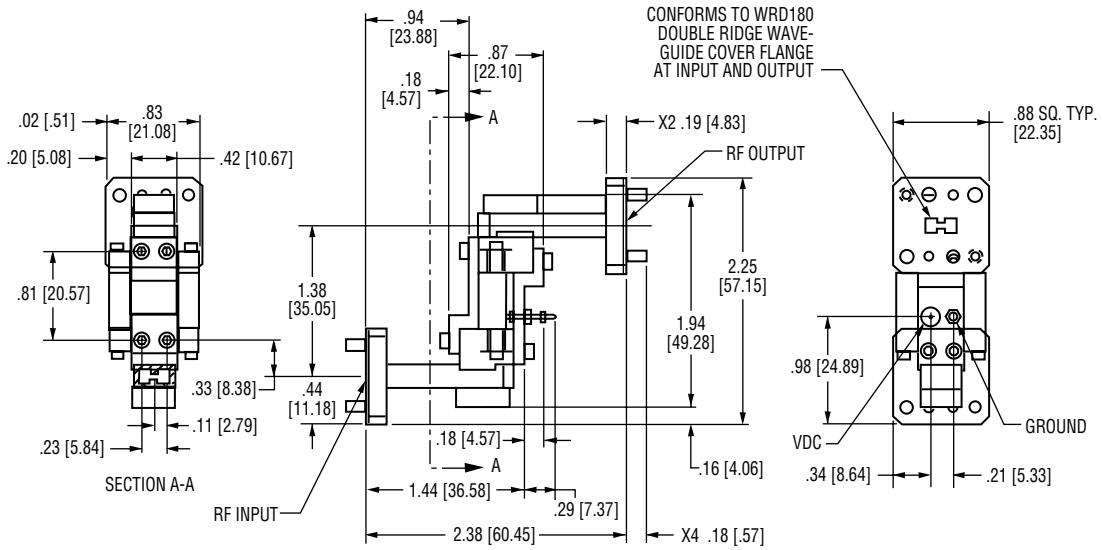

ULTRA-LOW NOISE X-BAND SATCOM LNA

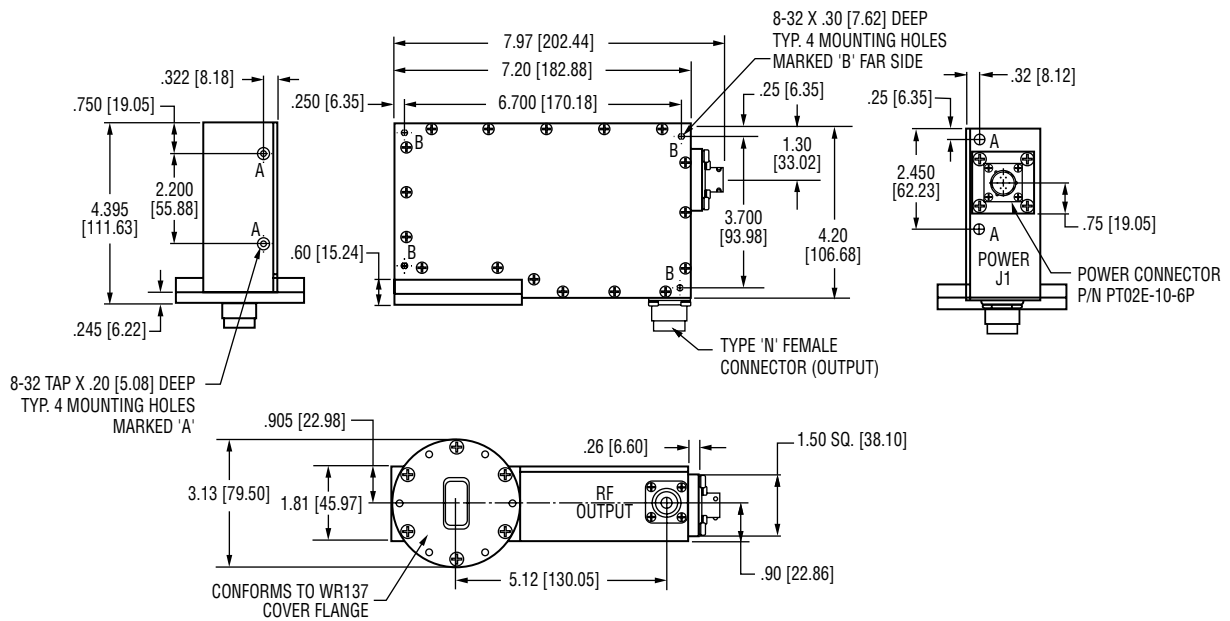

NOTE: DIMENSIONS SHOWN IN BRACKETS [] ARE IN MILLIMETERS.



JS DEPARTMENT

TEL: (631) 439-9474
 FAX: (631) 435-7470
 E-MAIL: acollins@miteq.com

DATE _____

COMPANY _____

ADDRESS _____

CONTACT _____

TEL. _____

FAX _____

E-MAIL _____

SPECIFICATION PARAMETER	APPLICATION #1	APPLICATION #2
Frequency		
Gain (dB, minimum)		
Gain flatness (\pm dB)		
Gain vs. temperature		
Noise figure @ temperature (dB, maximum)		
Operating temperature range		
Input VSWR (maximum)		
Output VSWR (maximum)		
Output power @ 1 dB compression (dBm, minimum)		
Output third order IP ³ (dBm, minimum)		
DC supply voltage, current		
Connectors (input/output)		
Size requirement, L/W/H		
Other (specify)		
Need date		
Quantity		

Other special requirements

OPTIONS

Connectors: SMA (standard), K connectors, V connectors, waveguide and pins.
 Screening: commercial (standard), MIL-STD-833, MIL-STD-38534, MIL-STD-810, etc.
 Special testing: shock, random vibration, thermal cycling, burn-in, etc.

For additional information please complete and FAX this form to [631] 435-7470, or call Ann Collins at [631] 439-9474

PLEASE SEND ADDITIONAL INFORMATION ON THE FOLLOWING MITEQ PRODUCTS:

- Amplifiers
- Mixers
- Multipliers
- Frequency Sources
- Passive Power Components
- IF Signal Processing Components
- Integrated Assemblies
- Fiber Optic Products
- SATCOM Products

