

2.8–9.9 GHz FREQUENCY MULTIPLEXER

MODEL: FMX-028099

FEATURES

- High reliability spaceborne application
- Broadband RF coverage 2.8–9.9 GHz
- RF gain 23 dB nominal
- Channel-to-channel isolation.. 45 dB minimum
- In/out VSWR..... 1.5:1 typical,
1.8:1 maximum
- Noise figure 3.5 dB typical,
4.5 dB maximum
- Low power 325 mA (5 V) typical

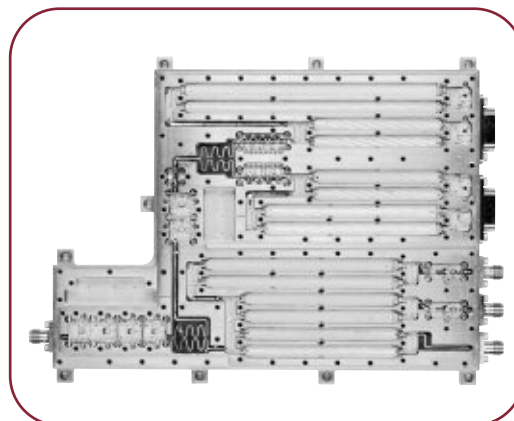

MITEQ's Model FMX-028099 broadband-three output frequency multiplexer precedes the second IF down conversion stage in a low earth orbit-based millimeter-wave radiometer. In combination with the MITEQ second IF downconverter, the system provides maximally flat frequency response over the bands of interest, high linearity of output power to input power, and high isolation between the frequency bands of interest as well as from other undesirable signals. In addition, this high reliability, spaceborne integrated assembly is optimized for small size, low power consumption, lightweight, and excellent gain stability.

ELECTRICAL SPECIFICATIONS

RF INPUT PARAMETERS	CONDITION	UNITS	MIN.	TYP.	MAX.
Frequency range		GHz	2.8		9.9
VSWR		Ratio		1.5:1	1.8:1
RF OUTPUT PARAMETERS	CONDITION	UNITS	MIN.	TYP.	MAX.
Number of RF output channels				3	
Channel 2 dB bandwidth		MHz	1300		
Channel 20 dB rejection bandwidth		MHz			2300
Channel center frequencies		GHz		3.9449, 5.7085, 9.1168	
Nominal gain		dB		23	
Output power (1 dB compression)		dBm	-8	-5	
Noise figure		dB		3.5	4.5
Isolation between output channels		dB	45		
VSWR	Over 1300 MHz passband	Ratio		1.5:1	1.8:1
VOLTAGE TO FREQUENCY OUTPUT PARAMETERS	CONDITION	UNITS	MIN.	TYP.	MAX.
Number of output channels				4	
Channel 3 dB bandwidth		MHz	450		
Channel 30 dB rejection bandwidth		MHz			1000
Channel center frequencies		GHz		3.06, 4.76, 7.26, 7.86	
Output full scale frequency		kHz		90	
OTHER PARAMETERS	CONDITION	UNITS	MIN.	TYP.	MAX.
Digital gain control	4 bit binary, TTL; bit 5 = OFF state	dB	0		7.5
Gain control step size		dB		0.5	
Connectors, RF				SMA	
Connectors, DC control, voltage-frequency outputs				21-pin, micro D	
Supply voltage		Volts		±5	
DC power consumption for each downconverter	At 5 V Supply	mA		325	
	At -5 V Supply	mA		2.5	
Weight		Grams		520	

FMX-028099

ENVIRONMENTAL CONDITIONS

Operating temperature 0 to 70°C
 Storage temperature -30 to +85°C
 Humidity 95% noncondensing
 Vibration 12 g's rms, 20-2000 Hz per MIL-STD-810B Method 514, Procedure 5

FUNCTIONAL BLOCK DIAGRAMS

GENERIC SYSTEM

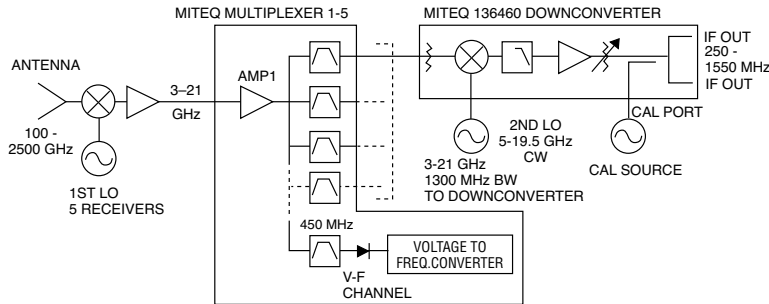

MODEL FMX-028099

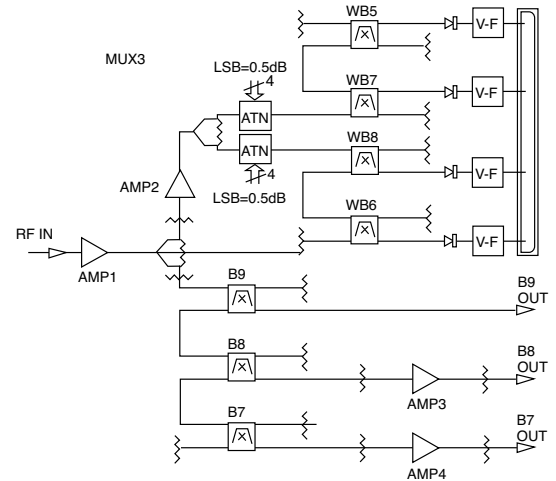

OUTLINE DRAWING

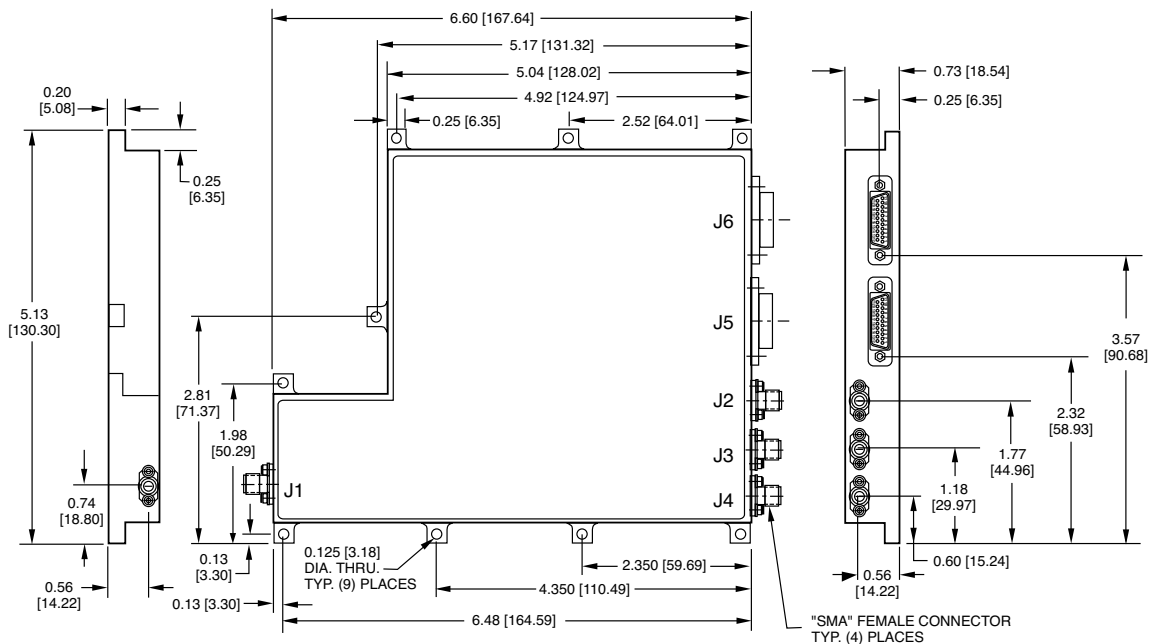

GENERAL NOTES:

- Dimensions shown in brackets [] are in millimeters.
- Tolerance as follows: .xx = ±0.01 [.xx = ±0.25], .xxx = ±0.005 [.xxx = ±0.13]



FMX-028099 TYPICAL TEST DATA

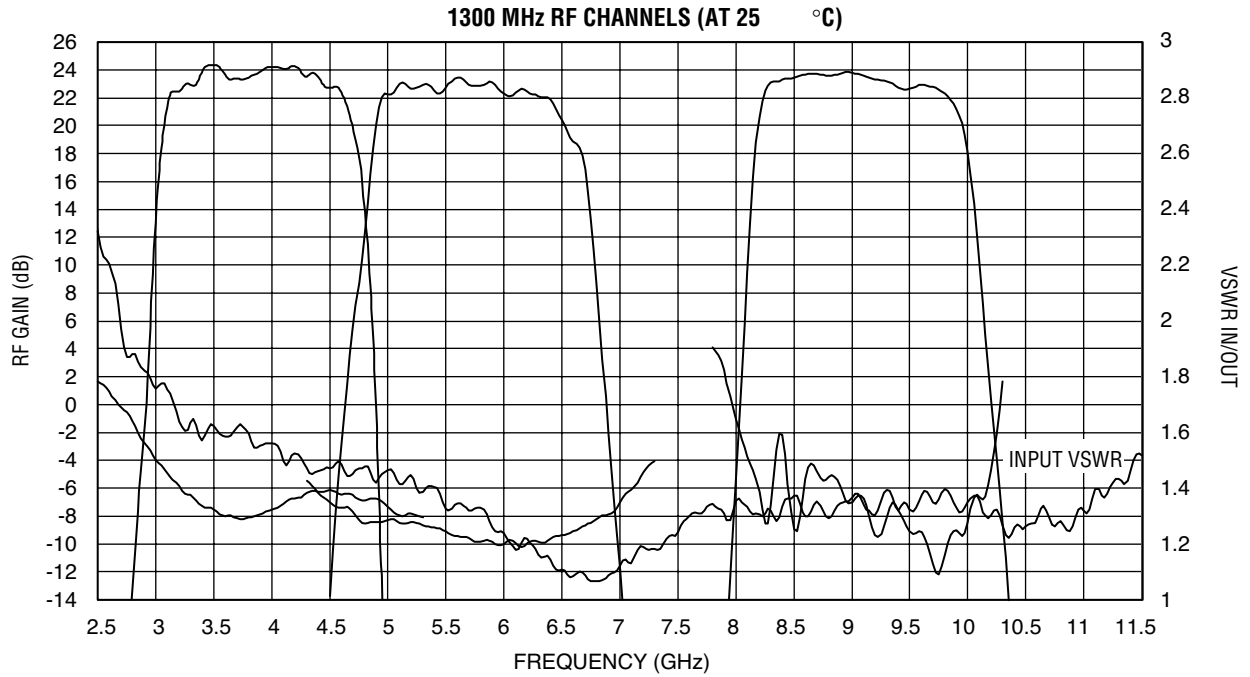

450 MHz DETECTED VOLTAGE TO FREQUENCY OUTPUTS (AT 25 °C).

