

1 TO 4 GHz LINEAR RF BIPHASE MODULATOR

MODEL: BMA0104LA1MD (Modulation Driven)

FEATURES

- RF frequency range 1 to 4 GHz
- Modulation bandwidth DC to 1 GHz
- Biphase accuracy $\pm 1^\circ$
- Amplitude accuracy ± 0.1 dB
- Modulator to RF isolation 40 dB

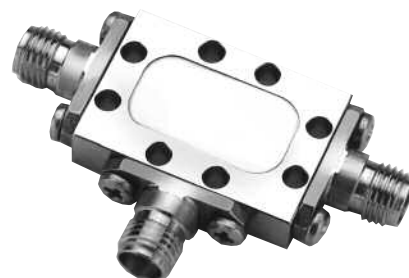

The unusually high port-to-port isolation of MITEQ's BMA Series of biphase modulators makes them well-suited for directly modulating microwave carriers in the linear RF or linear IF modulation modes. The latter or carrier driven mode is useful for low BER digital transmission using Gaussian shaped pulses for minimum bandwidth. Optional diodes are available for more output power using proportionally greater input LO or carrier power. TTL drivers are also available (BMT Series). The specifications shown below are for the modulation driven mode (linear RF). An optional model (-CD) can be ordered and tested in the carrier driven or linear modulation mode.

ELECTRICAL SPECIFICATIONS

INPUT PARAMETERS	CONDITION	UNITS	MIN.	TYP.	MAX.
RF frequency range		GHz	1		4
RF power		dBm	Noise		+5
RF VSWR	1.25 to 3.75 GHz	Ratio		2:1	
IF frequency range		GHz	DC		1
IF current (antiparallel diode input)		mA	-10		+10
TRANSFER CHARACTERISTICS	CONDITION	UNITS	MIN.	TYP.	MAX.
Biphase accuracy	1 to 4 GHz	Degrees		1	3
	1.5 to 3 GHz			0.5	2
Biphase amplitude balance	IF = ± 10 mA	dB		0.1	0.3
Switch loss	IF = ± 10 mA	dB		4	5
Isolation	RF in to RF out	RF = +10, IF = Off	30	35	
	IF in to RF in	RF = +10, IF = Off		40	
	IF in to RF out	RF = +10, IF = Off		40	
OUTPUT PARAMETERS	CONDITION	UNITS	MIN.	TYP.	MAX.
RF frequency range (modulated carrier)	1.25 to 3.75	GHz	1		4
RF power at 1 dB compression		dBm		0	
RF VSWR	Mode 2	Ratio		1.5:1	

BMA0104LA1MD MODULATION DRIVEN TYPICAL TEST DATA

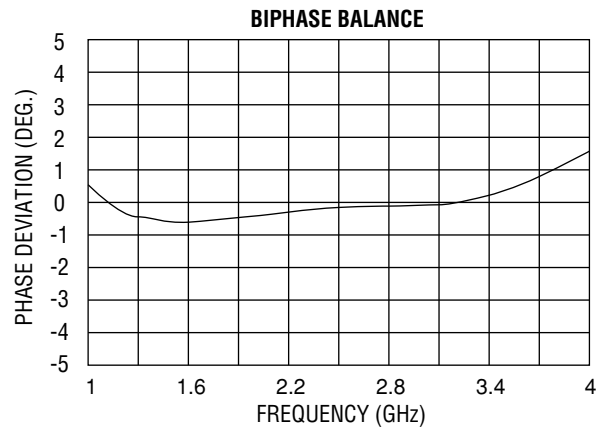
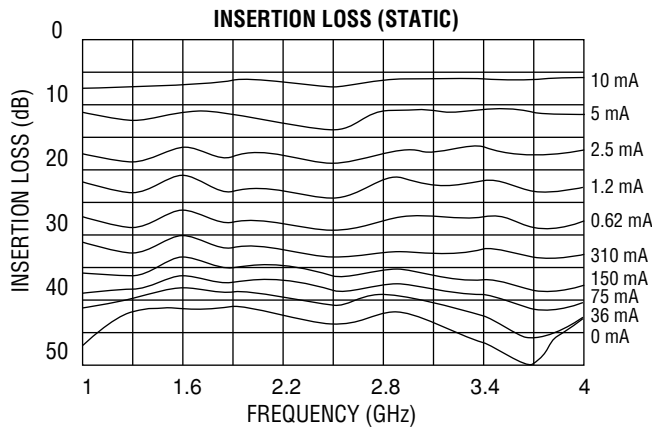
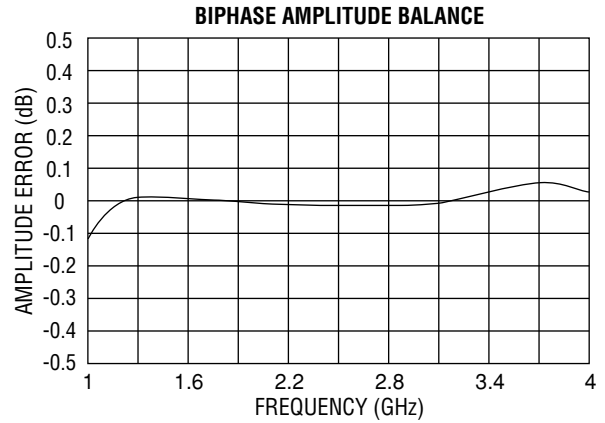
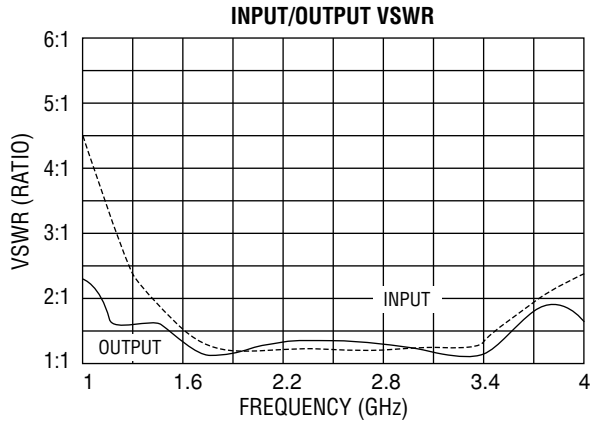

MAXIMUM RATINGS

Specification temperature +25°C
 Operating temperature -54 to +85°C
 Storage temperature -65 to +95°C

GENERAL NOTE

1. Linear RF or modulation driven mode (RF = 0 dBm, IF = ±10 mA).

NOTE: Test data supplied at 25°C; insertion loss and biphas accuracy.

OUTLINE DRAWING

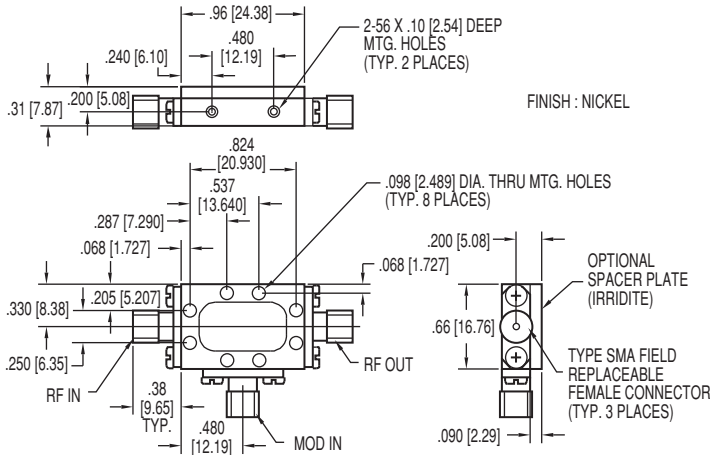

BLOCK DIAGRAM

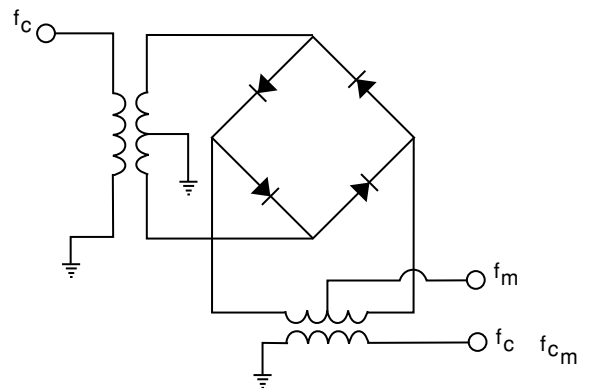

NOTE: All dimensions shown in brackets [] are in millimeters.