

# MITEQ AM-1618 SERIES AMPLIFIER

FREQUENCY (MHz)	MODEL NUMBER	GAIN (dB) (Min.)	VAR. (±dB) (Max.)	VSWR (Max.)	IMPED. IN/OUT (Ohms)	NOISE FIGURE (dB, Typ.)	P1 dB (dBm) (Typ.)	VOLTS	NOM. DC POWER (mA)	OUTLINE NO.
20-1000	AM-1618-1000	21	0.5	2.0:1	50/50	3.1	14	15	60	1
20-2000	AM-1618-2000	21	0.75	2.0:1	50/50	3.4	14	15	60	1
20-2500	AM-1618-2500	21	1.5	2.0:1	50/50	3.5	13	15	60	1
20-3000	AM-1618-3000	20	2.0	2.0:1	50/50	3.6	13	15	60	1

Gain (dB)

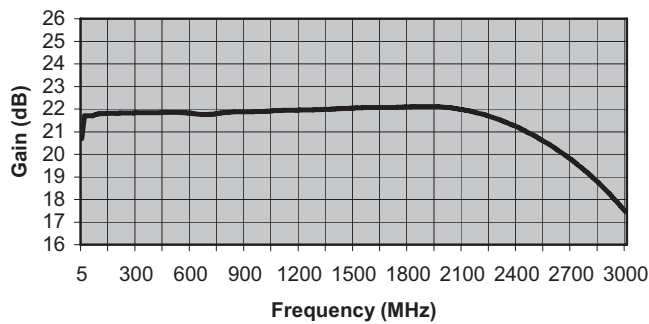

Input & Output Return Loss (dBRL)

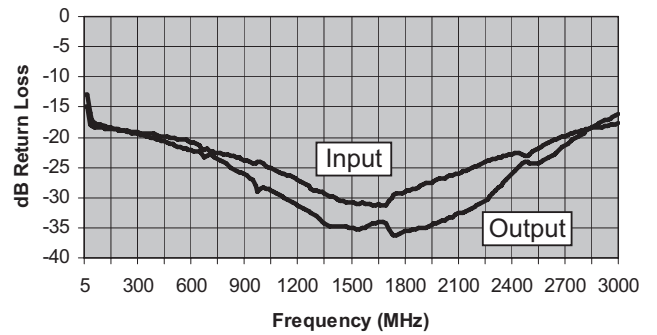

Noise Figure (dB)

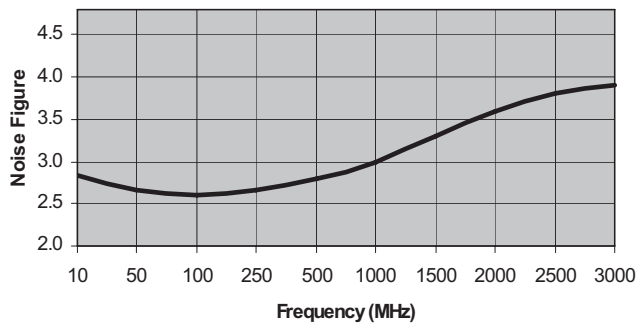

Output -1dB Gain Compression (+dBm)

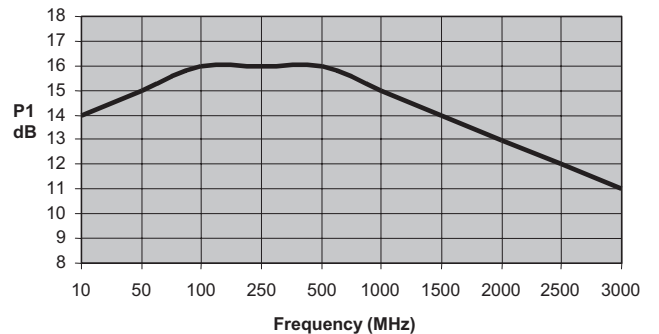

Reverse Isolation (dB)

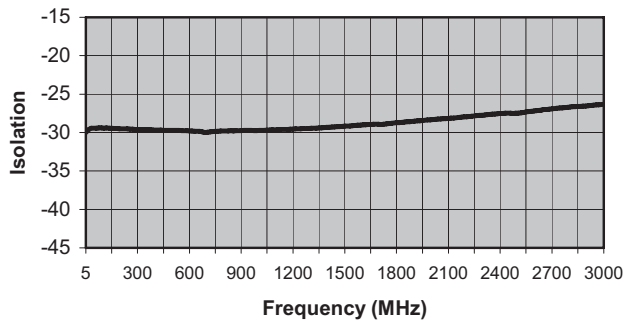

Third Order Intercept (+dBm)

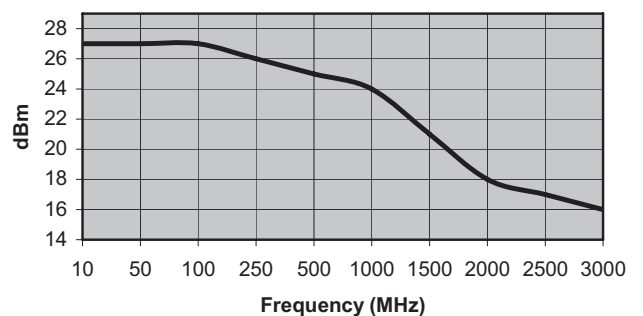

ISO 9001:2000 Certified • General Information • Warranty



100 Davids Drive, Hauppauge, NY 11788  
 TEL.: (631) 439-9220 • FAX: (631) 436-7430  
 e-mail: components@miteq.com • www.miteq.com

## MITEQ AM-1618 SERIES AMPLIFIER

(MHz)	(dB)
5	20.7
10	21.7
30	21.7
45	21.7
60	21.7
75	21.7
90	21.8
105	21.8
120	21.8
135	21.8
150	21.8
165	21.8
180	21.8
195	21.8
210	21.8
225	21.8
240	21.8
255	21.8
270	21.8
285	21.8
300	21.8
315	21.8
330	21.8
345	21.8
360	21.8
375	21.8
390	21.8
405	21.8
420	21.8
435	21.8
450	21.8
465	21.8
480	21.8
495	21.8
510	21.8
525	21.8
540	21.8
555	21.8
570	21.8
585	21.8
600	21.8
615	21.8
630	21.8
645	21.8
660	21.8
675	21.8
690	21.8
705	21.8
720	21.8
735	21.8
750	21.8
765	21.8
780	21.8
795	21.8
810	21.9

(MHz)	(dB)
825	21.9
840	21.9
855	21.9
870	21.9
885	21.9
900	21.9
915	21.9
930	21.9
945	21.9
960	21.9
975	21.9
990	21.9
1005	21.9
1020	21.9
1035	21.9
1050	21.9
1065	21.9
1080	21.9
1095	21.9
1110	21.9
1125	21.9
1140	21.9
1155	21.9
1170	22.0
1185	22.0
1200	22.0
1215	22.0
1230	22.0
1245	22.0
1260	22.0
1275	22.0
1290	22.0
1305	22.0
1320	22.0
1335	22.0
1350	22.0
1365	22.0
1380	22.0
1395	22.0
1410	22.0
1425	22.0
1440	22.0
1455	22.0
1470	22.0
1485	22.0
1500	22.0
1515	22.0
1530	22.1
1545	22.1
1560	22.1
1575	22.1
1590	22.1
1605	22.1
1620	22.1
1635	22.1

(MHz)	(dB)
1650	22.1
1665	22.1
1680	22.1
1695	22.1
1710	22.1
1725	22.1
1740	22.1
1755	22.1
1770	22.1
1785	22.1
1800	22.1
1815	22.1
1830	22.1
1845	22.1
1860	22.1
1875	22.1
1890	22.1
1905	22.1
1920	22.1
1935	22.1
1950	22.1
1965	22.1
1980	22.1
1995	22.1
2010	22.1
2025	22.1
2040	22.1
2055	22.0
2070	22.0
2085	22.0
2100	22.0
2115	22.0
2130	21.9
2145	21.9
2160	21.9
2175	21.8
2190	21.8
2205	21.8
2220	21.8
2235	21.7
2250	21.7
2265	21.6
2280	21.6
2295	21.6
2310	21.5
2325	21.5
2340	21.4
2355	21.4
2370	21.3
2385	21.3
2400	21.2
2415	21.2
2430	21.1
2445	21.0
2460	21.0

(MHz)	(dB)
2475	20.9
2490	20.9
2505	20.8
2520	20.7
2535	20.6
2550	20.6
2565	20.5
2580	20.4
2595	20.4
2610	20.3
2625	20.2
2640	20.1
2655	20.0
2670	19.9
2685	19.9
2700	19.8
2715	19.7
2730	19.6
2745	19.5
2760	19.4
2775	19.3
2790	19.2
2805	19.1
2820	19.0
2835	18.9
2850	18.7
2865	18.6
2880	18.5
2895	18.4
2910	18.3
2925	18.1
2940	18.0
2955	17.9
2970	17.7
2985	17.6
3000	17.5

5/2/2007



**100 Davids Drive, Hauppauge, NY 11788**  
**TEL.: (631) 439-9220 • FAX: (631) 436-7430**  
**e-mail: components@miteq.com • www.miteq.com**

## MITEQ AM-1618 SERIES AMPLIFIER

Freq (MHz)	VSWR (dBRL)	VSWR (dBRL)
5	-15	-13
10	-15	-13
30	-18	-16
45	-18	-17
60	-18	-18
75	-18	-18
90	-18	-18
105	-19	-18
120	-19	-18
135	-19	-18
150	-19	-18
165	-19	-19
180	-19	-19
195	-19	-19
210	-19	-19
225	-19	-19
240	-19	-19
255	-19	-19
270	-19	-19
285	-19	-19
300	-19	-19
315	-19	-20
330	-19	-20
345	-19	-20
360	-19	-20
375	-19	-20
390	-19	-20
405	-20	-20
420	-20	-20
435	-20	-21
450	-20	-21
465	-20	-21
480	-20	-21
495	-20	-21
510	-20	-21
525	-20	-22
540	-20	-22
555	-20	-22
570	-20	-22
585	-21	-22
600	-21	-22
615	-21	-22
630	-21	-22
645	-21	-22
660	-22	-23
675	-22	-23
690	-22	-23
705	-22	-23
720	-22	-23
735	-23	-23
750	-23	-24
765	-23	-24
780	-23	-24
795	-23	-24

Freq (MHz)	VSWR (dBRL)	VSWR (dBRL)
810	-23	-25
825	-23	-25
840	-23	-25
855	-23	-25
870	-23	-26
885	-24	-26
900	-24	-26
915	-24	-26
930	-24	-27
945	-24	-27
960	-24	-28
975	-24	-29
990	-24	-29
1005	-24	-28
1020	-25	-29
1035	-25	-29
1050	-25	-29
1065	-25	-29
1080	-26	-29
1095	-26	-30
1110	-26	-30
1125	-26	-30
1140	-26	-30
1155	-26	-31
1170	-27	-31
1185	-27	-31
1200	-27	-31
1215	-27	-32
1230	-28	-32
1245	-28	-32
1260	-28	-32
1275	-29	-32
1290	-29	-33
1305	-29	-33
1320	-29	-34
1335	-29	-34
1350	-29	-34
1365	-30	-34
1380	-30	-35
1395	-30	-35
1410	-30	-35
1425	-30	-35
1440	-30	-35
1455	-31	-35
1470	-31	-35
1485	-31	-35
1500	-31	-35
1515	-31	-35
1530	-31	-35
1545	-31	-35
1560	-31	-35
1575	-31	-35
1590	-31	-35
1605	-31	-34

Freq (MHz)	VSWR (dBRL)	VSWR (dBRL)
1620	-31	-34
1635	-31	-34
1650	-31	-34
1665	-31	-34
1680	-31	-34
1695	-31	-34
1710	-31	-35
1725	-30	-36
1740	-30	-36
1755	-29	-36
1770	-29	-36
1785	-29	-36
1800	-29	-36
1815	-29	-35
1830	-29	-35
1845	-29	-35
1860	-28	-35
1875	-28	-35
1890	-28	-35
1905	-28	-35
1920	-28	-35
1935	-28	-35
1950	-27	-35
1965	-27	-34
1980	-27	-34
1995	-27	-34
2010	-27	-34
2025	-27	-34
2040	-27	-34
2055	-26	-33
2070	-26	-33
2085	-26	-33
2100	-26	-33
2115	-26	-32
2130	-26	-32
2145	-25	-32
2160	-25	-32
2175	-25	-32
2190	-25	-32
2205	-25	-31
2220	-25	-31
2235	-24	-31
2250	-24	-31
2265	-24	-30
2280	-24	-30
2295	-24	-29
2310	-24	-29
2325	-23	-28
2340	-23	-28
2355	-23	-28
2370	-23	-27
2385	-23	-27
2400	-23	-26
2415	-23	-26

Freq (MHz)	VSWR (dBRL)	VSWR (dBRL)
2430	-23	-25
2445	-23	-25
2460	-23	-24
2475	-23	-24
2490	-23	-24
2505	-23	-24
2520	-22	-24
2535	-22	-24
2550	-22	-24
2565	-22	-24
2580	-21	-24
2595	-21	-24
2610	-21	-23
2625	-21	-23
2640	-20	-23
2655	-20	-23
2670	-20	-22
2685	-20	-22
2700	-20	-21
2715	-20	-21
2730	-19	-21
2745	-19	-20
2760	-19	-20
2775	-19	-20
2790	-19	-20
2805	-19	-19
2820	-19	-19
2835	-19	-19
2850	-18	-18
2865	-18	-18
2880	-18	-18
2895	-18	-18
2910	-18	-17
2925	-18	-17
2940	-18	-17
2955	-18	-17
2970	-18	-17
2985	-18	-16
3000	-18	-16

5/2/2007



**100 Davids Drive, Hauppauge, NY 11788**  
**TEL.: (631) 439-9220 • FAX: (631) 436-7430**  
**e-mail: components@miteq.com • www.miteq.com**

## MITEQ AM-1618 SERIES AMPLIFIER

Freq. (MHz)	Isolation (dB)
5	-30
10	-29
30	-29
45	-29
60	-29
75	-29
90	-29
105	-29
120	-29
135	-29
150	-29
165	-29
180	-30
195	-30
210	-30
225	-30
240	-30
255	-30
270	-30
285	-30
300	-30
315	-30
330	-30
345	-30
360	-30
375	-30
390	-30
405	-30
420	-30
435	-30
450	-30
465	-30
480	-30
495	-30
510	-30
525	-30
540	-30
555	-30
570	-30
585	-30
600	-30
615	-30
630	-30
645	-30
660	-30
675	-30
690	-30
705	-30
720	-30
735	-30
750	-30
765	-30
780	-30
795	-30

Freq. (MHz)	Isolation (dB)
810	-30
825	-30
840	-30
855	-30
870	-30
885	-30
900	-30
915	-30
930	-30
945	-30
960	-30
975	-30
990	-30
1005	-30
1020	-30
1035	-30
1050	-30
1065	-30
1080	-30
1095	-30
1110	-30
1125	-30
1140	-30
1155	-30
1170	-30
1185	-30
1200	-30
1215	-30
1230	-30
1245	-29
1260	-29
1275	-29
1290	-29
1305	-29
1320	-29
1335	-29
1350	-29
1365	-29
1380	-29
1395	-29
1410	-29
1425	-29
1440	-29
1455	-29
1470	-29
1485	-29
1500	-29
1515	-29
1530	-29
1545	-29
1560	-29
1575	-29
1590	-29
1605	-29

Freq. (MHz)	Isolation (dB)
1620	-29
1635	-29
1650	-29
1665	-29
1680	-29
1695	-29
1710	-29
1725	-29
1740	-29
1755	-29
1770	-29
1785	-29
1800	-29
1815	-29
1830	-29
1845	-29
1860	-29
1875	-29
1890	-29
1905	-29
1920	-28
1935	-28
1950	-28
1965	-28
1980	-28
1995	-28
2010	-28
2025	-28
2040	-28
2055	-28
2070	-28
2085	-28
2100	-28
2115	-28
2130	-28
2145	-28
2160	-28
2175	-28
2190	-28
2205	-28
2220	-28
2235	-28
2250	-28
2265	-28
2280	-28
2295	-28
2310	-28
2325	-28
2340	-28
2355	-28
2370	-28
2385	-28
2400	-28
2415	-28

Freq. (MHz)	Isolation (dB)
2430	-27
2445	-28
2460	-28
2475	-27
2490	-27
2505	-27
2520	-27
2535	-27
2550	-27
2565	-27
2580	-27
2595	-27
2610	-27
2625	-27
2640	-27
2655	-27
2670	-27
2685	-27
2700	-27
2715	-27
2730	-27
2745	-27
2760	-27
2775	-27
2790	-27
2805	-27
2820	-27
2835	-27
2850	-27
2865	-27
2880	-27
2895	-27
2910	-26
2925	-26
2940	-26
2955	-26
2970	-26
2985	-26
3000	-26

5/2/2007



**100 Davids Drive, Hauppauge, NY 11788**  
**TEL.: (631) 439-9220 • FAX: (631) 436-7430**  
**e-mail: components@miteq.com • www.miteq.com**

# MITEQ AM-1618 SERIES AMPLIFIER

OUTLINE	DIM A	DIM B	OUNCES
1	1.11 [28.19]	0.91 [23.11]	1.5

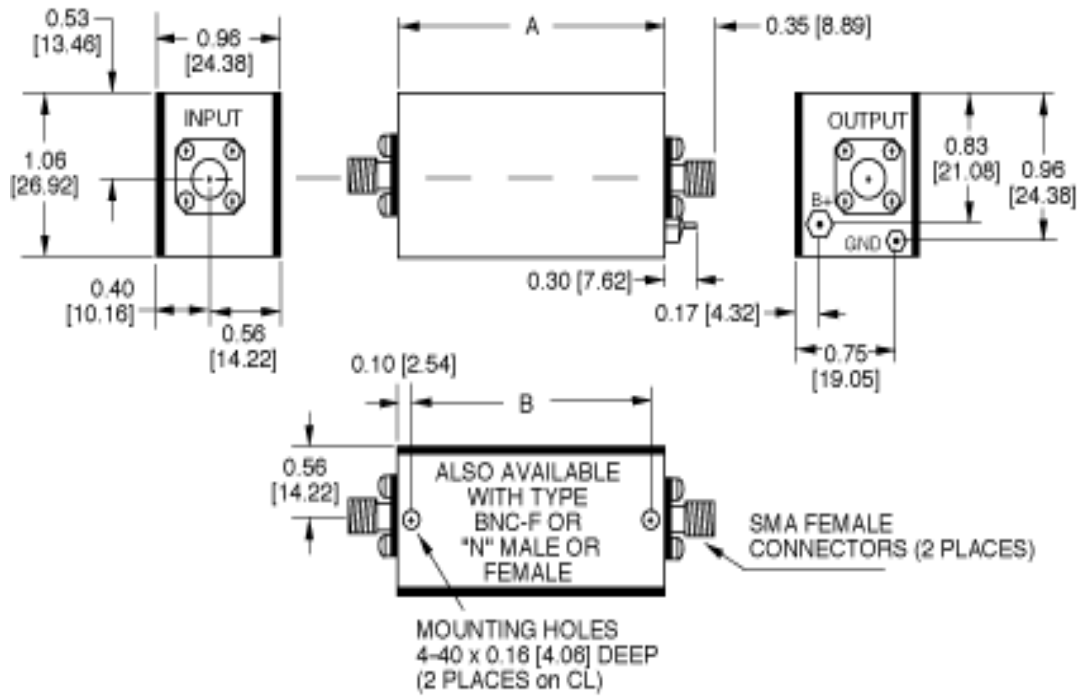

NOTE: DIMENSIONS ARE IN INCHES [MILLIMETERS].

## OPTIONS FOR BIPOLAR AMPLIFIERS

### INPUT BIAS TEE

#### Add Suffix "-F"

Used to inject bias signal to photo diode or other type of device. Check for availability on your model before ordering. Available on most units operating above 1 MHz. Please contact MITEQ with your custom requirements.

### BIAS THROUGH THE OUTPUT CONNECTOR

#### Add Suffix "-1306/E" or "-1306/D"

Used to supply operating power when the amplifier is remotely located while eliminating the need to run a separate DC line. Specify whether existing power pin should be "Enabled" or "Disabled." To order, add -1306/E or -1306/D after model number. Example: AU-2A-0150-1306/E will have existing +15 V pin enabled so that it can be used as a test point. Use caution with this option since any voltage applied here will also be present on the RF output center pin. Available on most units operating above 1 MHz.

### BIAS THROUGH THE OUTPUT CONNECTOR WITH DC FEEDTHROUGH TO RF INPUT

#### Add Suffix "-1334/E" or "-1334/D"

Used to supply operating power when the amplifier is remotely located and eliminates the need to run a separate DC line. This DC voltage is then internally fed to the RF input to power a remote LNA or other low power equipment. Maximum current of external load will vary with model type. Available on most units operating above 1 MHz. Please contact factory prior to ordering.

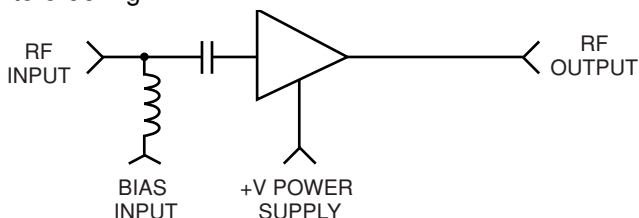

Specify whether existing power pin should be "Enabled" or "Disabled". To order, add "-1334/E" or "-1334/D"

after model number. Example: AU-2A-0150-1334/E will have existing +15 V pin enabled so that it can be used as a test point. Use caution with this option since any voltage applied here will also be present on both the RF output and input center pins.

### TYPE N OR BNC CONNECTORS

#### Add Suffix "-N" or "-BNC"

Type N-female and type BNC-female are available for all outlines 1 through 5, 12, 13 and 15 amplifiers. Add connector type after model number. Examples: AU-2A-0150-N; AU-2A-0150-BNC. Type N-male and mixed connector types are also available on request. Please call MITEQ with your specific requirements.

### INPUT INTERNAL LIMITER

#### Add Suffix "-1103"

Available on models up to 500 MHz. Will protect the input stage from CW signals as high as +30 dBm. To order, add "-1103" after model number. Example: AU-2A-0150-1103. Options are available for protection against short duration pulses up to 50 W.

### AC POWER SUPPLY (100 to 240 VAC, 47 - 440 Hz). Add Suffix "-1179"

Available as an add-on to most models using outlines 1 through 5 and 15. Includes 6-foot line cord with standard US line plug, internal fuse, on/off switch and LED indicator light. Amplifier is permanently mounted to power supply. To order, add "-1179" after model number. Example: AU-2A-0150-1179. Refer to outline 12 for dimensions.

### AC POWER SUPPLY (Wall plug-in unit) Part Number "205531-19"

A low cost alternate to option "-1179", the wall plug-in unit is a small switching power supply capable of delivering 1 amp at 15 volts.

### AC POWER SUPPLY WITH SMC CONNECTORS (Wall plug-in unit) Part Number "-1179SC"

Same as above except has mating SMC connectors on amplifier DC input and power supply DC output. Available for outlines 1 through 10, 13 and 15.

### ADDITIONAL OPTIONS AVAILABLE

OPTION	SUFFIX
Gain Window	-GW
Phase Match	-PM
Amplitude Match	-AM
Gain Control	-GC



## GENERAL INFORMATION

### PRICING AND TERMS

A quotation on any item in the catalog is available by contacting the factory. All quotations, unless otherwise noted, are valid for 60 days from the date of issue, F.O.B. (FCA) Hauppauge, NY 11788. Pricing does not include customer or government source inspection unless otherwise noted. On international orders, an irrevocable letter of credit may be required. MITEQ accepts these credit cards:

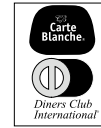

### QUANTITY DISCOUNTS

A quantity discount is generally available on most catalog items. Due to the wide variety of devices in the catalog, it is not possible to provide a standard discount schedule. When quantities are involved, please contact the factory and the appropriate information will be provided.

### SOURCE INSPECTION

Government / customer source inspection is available on any item upon receipt of the complete written confirmation of purchase order items, including the prime government contract number. Source inspection with respect to some products increases the unit price and extends delivery because of duplicate standard final inspection and testing. It is recommended wherever possible that a Certificate of Compliance be substituted for source inspection to minimize price and delivery delays.

### SHIPPING INFORMATION

Unless instructed otherwise by the customer, we will ship UPS in the U.S. F.O.B. (FCA) Hauppauge. Air freight will be used as the primary international means of shipment. Please indicate at time of purchase what method of shipment you require.

### RETURNED MATERIAL

When returning material for repair or replacement, please ensure that there is complete information included with the shipment, giving a detailed description of the reason for its return, the date and purchase order on which it was obtained, and the exact address to which the material is to be reshipped. All returns must arrive freight, postage, duties and handling prepaid.

### REPAIR COSTS

Warranty repairs will be made at no cost to the customer. Units out of warranty, or those which have been mishandled, will require approval by the customer for the charges involved before the repairs can be accomplished. We will provide an estimate for the cost of the repair, which can be applied to the repair, if approval is granted. For those items that are deemed beyond repair, or where the customer may decide not to repair the unit, an evaluation fee and handling charge will be applicable.

### APPLICATION ENGINEERING

We maintain a large support staff of engineers who are experts in specific areas of microwave technology. Each has an engineering background that combines both a formal engineering education with training and experience in product design. As further technical support, we make available the services of our engineering and scientific staff, who may be consulted on more advanced circuit designs or application problems.

### DRAWINGS AND SPECIFICATIONS

The material presented in this catalog was current at the time of publication. MITEQ Inc.'s continuing product improvement program makes it necessary to reserve the right to change our mechanical and electrical specifications without notice. If either of these parameters is critical, please contact the factory to verify that the information is current.

## ADDITIONAL INFORMATION

### WARRANTY

### ISO 9001:2000 Certified



### MITEQ FEDERAL SUPPLY CODE

Our Federal Supply Code is: 33592



100 Davids Drive, Hauppauge, NY 11788  
TEL.: (631) 439-9220 • FAX: (631) 436-7430  
e-mail: [components@miteq.com](mailto:components@miteq.com) • [www.miteq.com](http://www.miteq.com)