

- Airborne SatCom/Data Link
- Weather tight enclosure with hermetically sealed hybrid MIC
- Various waveguide flanges available
- Pressure windows available
- Temperature compensated
- Optional shielded DC power connector
- Available in WR42 or WR51

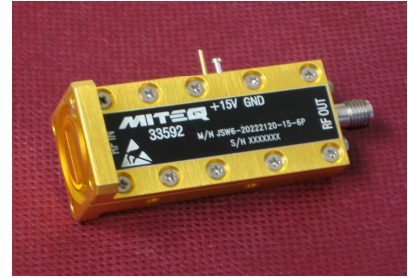

Specifications at +23°C

Parameter	Min	Typ	Max	Units
Frequency Range	20.2 to 21.2			GHz
Gain	48			dB
Gain Flatness			±0.5	dB
Noise Figure			1.5	dB
Input Return Loss			-14	dB
Output Return Loss			-14	dB
Output Power @ 1 dB Compression (P1dB)	8			dBm
Output Third Order (IP3)		18		dBm
DC Voltage		15		VDC
DC Current (mA)		150		mA
Operating Temperature	-54		+85	°C
Storage Temperature	-65		+125	°C

Outline (192043)

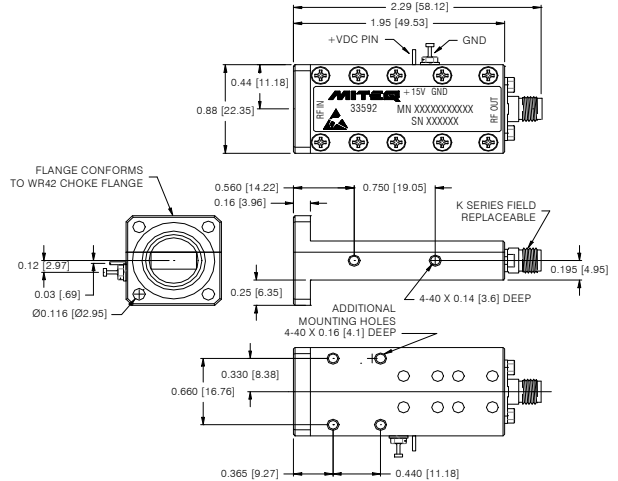

Typical Performance at +23°C

