

## Solid State PIN Control Products

2-18 GHz

### High Speed Switched-Bit Attenuators

- Very High Speed
- Precise Attenuation over Frequency Band
- Small Package Size
- Low Insertion Loss
- Hermetically Sealed

#### Options Available Based On Standard Designs

- Different Attenuation Range
- Performance Optimized over a Narrower Bandwidth
- Reverse Logic Control

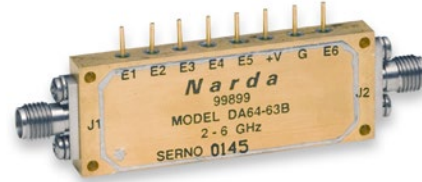

These miniature, high speed digitally controlled switched-bit attenuators are designed for operation over multi-octave bandwidths. Attenuation levels are guaranteed to be monotonic and selectable using standard TTL logic circuitry. All models are hermetically sealed and are specified to operate over the full temperature range. All attenuators are equipped with removable RF connectors and are suitable for drop-in applications.

#### **Digitally Controlled Attenuators (DCAs) vs Voltage Variable Attenuators (VVAs)**

A VVA allows the user to select any value within its rated attenuation range – the user has full analog control. Most VVAs operate by changing the bias current of the series and shunt PIN diodes that form attenuator pads. This design approach leads to significant errors in attenuation level over the operating bandwidth. The most demanding system requirements can only be met by using a look-up table to correct for these errors.

DCAs provide very precise attenuation levels in digital (binary) increments. They have extremely fast switching speeds compared to VVAs – typically ten to twenty times faster. These switched-bit attenuators combine one or more tandem pairs of SP2T PIN diode switches with a zero loss connection between one pair of outputs and a fixed attenuator inserted in the other. The PIN diodes are simply switched between their forward and reverse states, rather than being used as variable attenuators. Very high speed PIN diodes and control circuitry are used to operate all the bits in parallel.

The major disadvantages of DCAs versus VVAs are: the minimum practical attenuation level, higher cost due to more complex circuits, somewhat higher insertion loss, and the potential for video leakage due to the high speed switches. The smallest practical Least Significant Bit (LSB) is about 0.5 dB. Video filters can often be incorporated into the DCA to satisfy specific leakage requirements.

## Solid State PIN Control Products

## Specifications

SMA (F), 2-6 GHz

MODEL	DA14-25	DA24-15	DA34-7
FREQUENCY RANGE (GHz)	2-6	2-6	2-6
ATTENUATION RANGE (dB)	25	15	7
INSERTION LOSS (dB max.)	2.0	2.5	3.2
VSWR (max.)	1.8	1.8	1.8
NUMBER OF BITS	1	2	3
LSB - LEAST SIGNIFICANT BIT (dB)	25	5	1
ACCURACY OF MEAN ATTENUATION	±0.5 dB	±0.3 dB	±0.3 dB
ATTENUATION FLATNESS	±1.0 dB	±0.3 dB: 0 to 10 dB ±0.9 dB: 10 to 15 dB	±0.4 dB
POWER HANDLING	+23 dBm	+23 dBm	+23 dBm
SWITCHING TIME	30 ns (50% TTL to 10%/90% RF)	30 ns (50% TTL to 10%/90% RF)	30 ns (50% TTL to 10%/90% RF)
RISE AND FALL TIME (ns)	15	15	15
SWITCH RATE (MHz)	4.0	4.0	4.0
CONTROL LOGIC	'1' = I.L. '0' = ATTEN.	'1' = I.L. '0' = ATTEN.	'1' = I.L. '0' = ATTEN.
CONTROL INPUT	TRUE TTL GATE	TRUE TTL GATE	TRUE TTL GATE
POWER SUPPLY	+5 V ±2% @ 60 mA -12 V ±5% @ 60 mA	+5 V ±2% @ 110 mA -12 V ±5% @ 75 mA	+5V ±2% @ 180 mA -12V ±2% @ 130 mA
PIN DESIGNATIONS:			
E1	25 dB	5 dB	1 dB
E2	—	10 dB	2 dB
E3	—	—	4 dB
E4	—	—	—
E5	—	—	—
E6	—	—	—
E7	—	—	—
+V	+5V	+5V	+5V
-V	-12V	-12V	—
G	GROUND	GROUND	GROUND

## NOTE:

Monotonicity Guaranteed

## Solid State PIN Control Products

### Specifications (con't.)

SMA (F), 2-6 GHz

MODEL	DA64-63B	DA74-81	DA84-64
FREQUENCY RANGE (GHz)	2-6	2-6	2-6
ATTENUATION RANGE (dB)	63	81	63.75
INSERTION LOSS (dB max.)	4.3	5.5	6.5
VSWR (max.)	2.0	2.0	2.0
NUMBER OF BITS	6	7	8
LSB - LEAST SIGNIFICANT BIT (dB)	1	1	0.25
ACCURACY OF MEAN ATTENUATION	±0.5 dB : 0 to 31 dB ±1.0 dB : 31 to 63 dB	±0.5 dB : 0 to 21 dB ±1.0 dB : 22 to 41 dB ±1.5 dB : 42 to 81 dB	±0.5 dB : 0 to 21 dB ±1.0 dB : 22 to 41 dB ±1.5 dB : 42 to 63.75 dB
ATTENUATION FLATNESS	±0.5 dB : 0 to 15 dB ±0.75 dB : 15 to 32 dB ±1.0 dB : 32 to 63 dB	±0.5 dB : 0 to 21 dB ±0.75 dB : 22 to 41 dB ±1.0 dB : 42 to 81 dB	±0.5 dB : 0 to 21 dB ±0.75 dB : 22 to 41 dB ±1.0 dB : 42 to 63.75 dB
POWER HANDLING	+23 dBm	+23 dBm	+23 dBm
SWITCHING TIME	30 ns (50% TTL to 10%/90% RF)	500 ns	500 ns
RISE AND FALL TIME (ns)	10	—	—
SWITCH RATE (MHz)	4.0	0.5	0.4
CONTROL LOGIC*	'0' = I.L. '1' = ATTEN.	'1' = I.L. '0' = ATTEN.	'1' = I.L. '0' = ATTEN.
CONTROL INPUT	TRUE TTL GATE	TRUE TTL GATE	TRUE TTL GATE
POWER SUPPLY	+5 V ±2% @ 350 mA	+5 V ±2% @ 400 mA	+5 V ±2% @ 450 mA
PIN DESIGNATIONS:			
E1	1 dB	1 dB	0.25 dB
E2	2 dB	2 dB	0.5 dB
E3	4 dB	4 dB	1 dB
E4	8 dB	8 dB	2 dB
E5	16 dB	10 dB	4 dB
E6	32 dB	20 dB	8 dB
E7	—	40 dB	16 dB
E8	—	—	32 dB
+V	+5V	+5V	—
-V	—	—	—
G	GROUND	GROUND	GROUND

\* Reverse Logic available

NOTE:  
Monotonicity Guaranteed

## Solid State PIN Control Products

## SMA (F), 2-18 GHz

MODEL	DA13-25	DA26-15	DA36-7	DA66-63
FREQUENCY RANGE (GHz)	2-18	6-18	6-18	6-18
ATTENUATION RANGE (dB)	25	15	7.0	63
INSERTION LOSS (dB max.)	2.6	4.5	6.5	13
VSWR (max.)	2.0	2.0	2.0	2.0
NUMBER OF BITS	1	2	3	6
LSB - LEAST SIGNIFICANT BIT (dB)	25	5	1	1
ACCURACY OF MEAN ATTENUATION	±0.5 dB	±1 dB	±0.5 dB	±0.6 dB 0 to 15 dB ±1.0 dB 16 to 32 dB ±1.5 dB 33 to 63 dB
ATTENUATION FLATNESS	±1.5 dB	±0.6 dB @ 5 dB ±1.0 dB @ 10 dB ±1.5 dB @ 15 dB	±0.75 dB	±1.5 dB
POWER HANDLING	+23 dBm	+23 dBm	+23 dBm	+23 dBm
SWITCHING TIME	30 ns	30 ns (50% TTL to 10%/90% RF)	30 ns max.	30 ns
RISE AND FALL TIME (ns)	15	15	15	15
SWITCH RATE (MHz)	4.0	4.0	4.0	4.0
CONTROL LOGIC*	'1' = I.L. '0' = ATTEN.	'1' = I.L. '0' = ATTEN.	'1' = I.L. '0' = ATTEN.	'1' = I.L. '0' = ATTEN.
CONTROL INPUT	TRUE TTL GATE	TRUE TTL GATE	TRUE TTL GATE	TRUE TTL GATE
POWER SUPPLY	+5 V ±2% @ 60 mA -12 V ±5% @ 60 mA	+5 V ±2% @ 110 mA -12 V ±5% @ 75 mA	+5 V ±2% @ 200 mA -12 V ±2% @ 150 mA	+5 V ±2% @ 450 mA -12 V ±2% @ 300 mA
PIN DESIGNATIONS:				
E1	25 dB	5 dB	1 dB	1 dB
E2	—	10 dB	2 dB	2 dB
E3	—	—	4 dB	4 dB
E4	—	—	—	8 dB
E5	—	—	—	10 dB
E6	—	—	—	32 dB
+V	+5V	+5V	+5V	+5V
-V	-12V	-12V	-12V	-12V
G	GROUND	GROUND	GROUND	GROUND

\* Reverse Logic available

## NOTE:

Monotonicity Guaranteed

# Solid State PIN Control Products

## Environmental Specifications

### TEMPERATURE

Operating ..... -54°C to +95°C  
 Storage ..... -65°C to +125°C

### HUMIDITY

Per MIL-STD-202F, method 103B, condition B  
 (96 hours at 95% R.H.)

### SHOCK

Per MIL-STD-202F, method 213B, condition B  
 (75 G, 6 msec)

### ALTITUDE

Per MIL-STD-202F, method 105C, condition B  
 (50,000 feet)

### VIBRATION

Per MIL-STD-202F, method 204D, condition B  
 (.06" double amplitude or 15 G, whichever is less)

### THERMAL SHOCK

Per MIL-STD-202F, method 107D, condition A (5 cycles)

## Outline Drawings

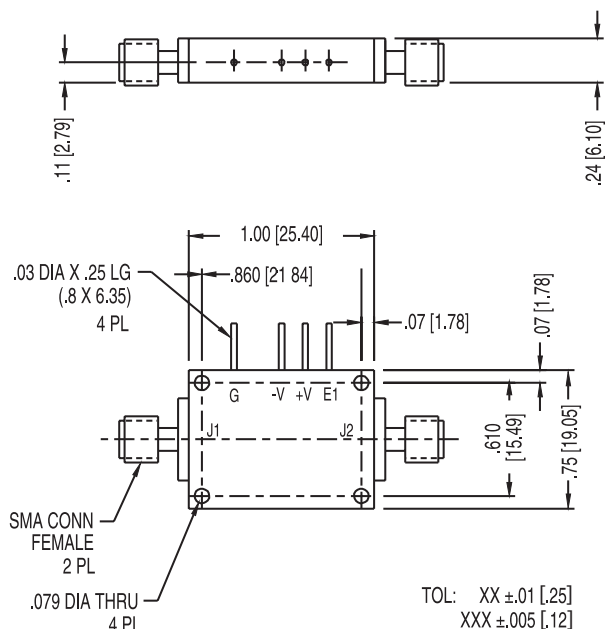

DA14-25, DA13-25

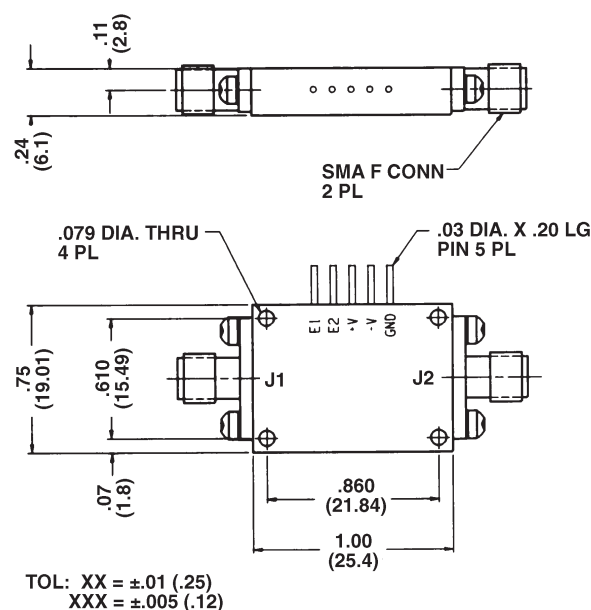

DA24-15, DA26-15

Dimensions in inches (mm in parentheses), unless otherwise specified.

# Solid State PIN Control Products

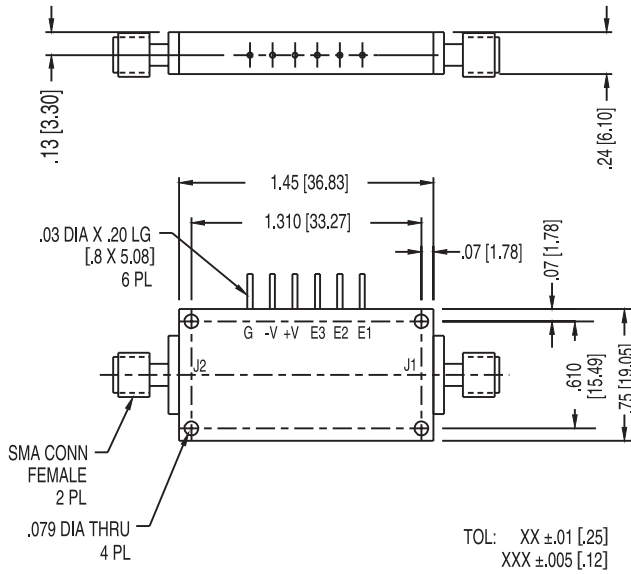

DA34-7, DA36-7

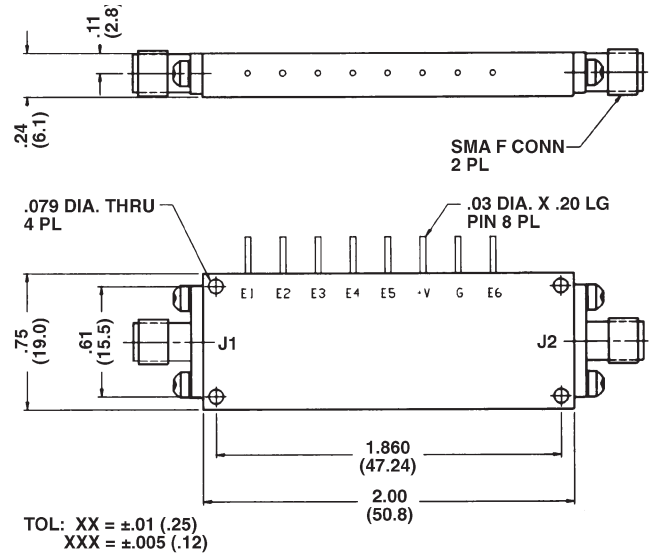

DA64-63B

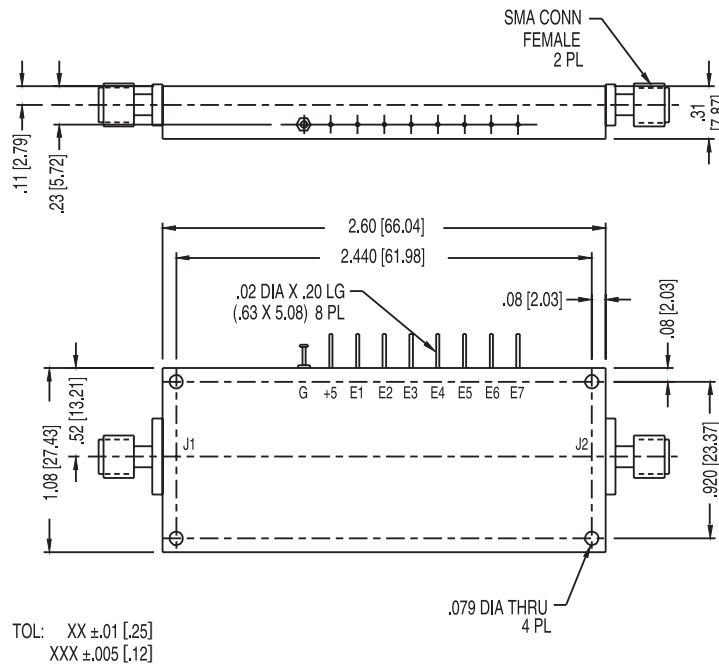

DA74-81

Dimensions in inches (mm in parentheses), unless otherwise specified.

# Solid State PIN Control Products

## Outline Drawings

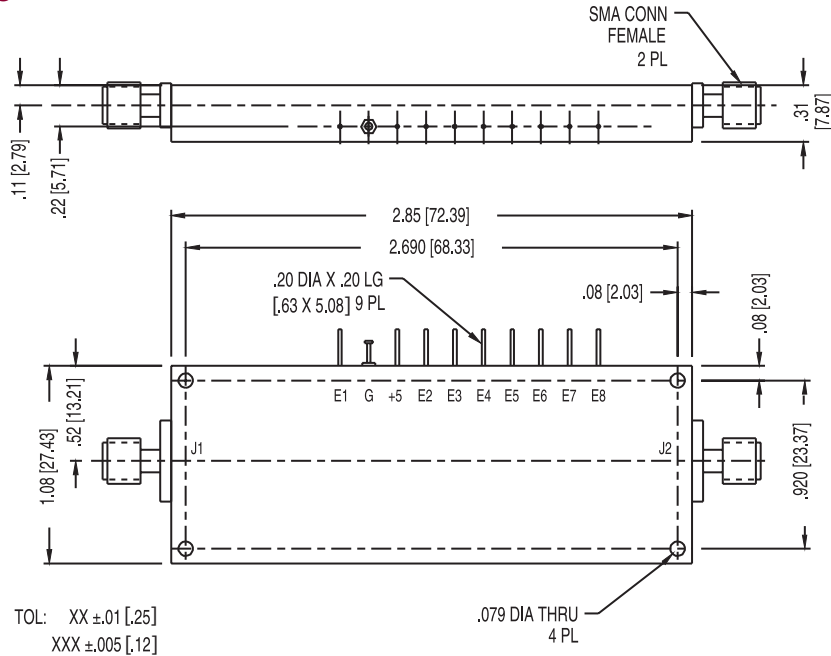

DA84-64

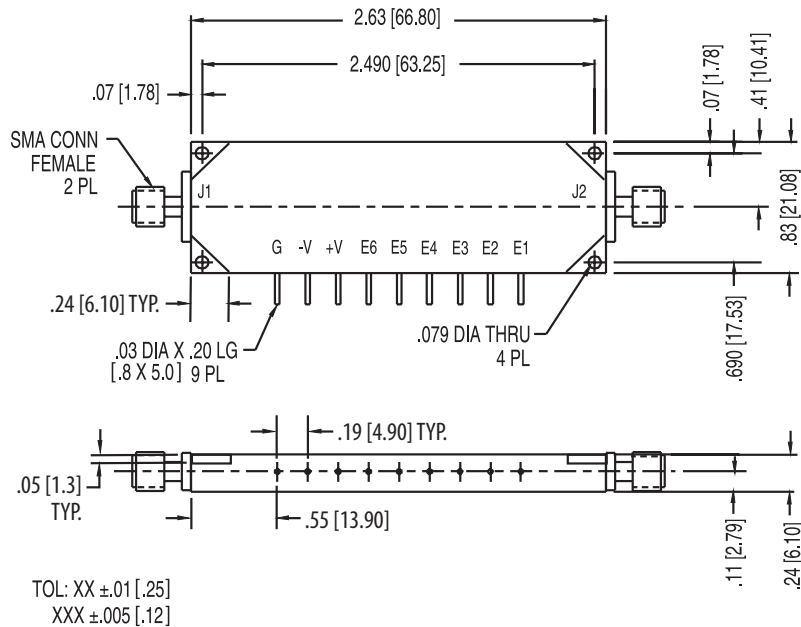

DA66-63

Dimensions in inches (mm in parentheses), unless otherwise specified.