



Back to

**Communication
Products Group**

Technical Notes

**25T020 Enhanced Automatic Frequency Control
For Inmarsat Earth Stations**

ENHANCED AUTOMATIC FREQUENCY CONTROL FOR INMARSAT EARTH STATIONS

1.0 INTRODUCTION

The purpose of this document is to explain the principles of operation of an enhanced AFC receiver for INMARSAT.

Summary

The EAFC system is designed such that:

1. The frequency of the carrier transmitted from the earth station to the mobile terminal is correct as it leaves the satellite.
2. The frequency of the received carrier demodulated at the earth station is correct.

2.0 THE PURPOSE OF AFC

A system such as INMARSAT transmits information in a series of closely spaced narrowband carriers. Each carrier represents one phone circuit. Shifting this series of carriers off frequency by even a few kHz would cause unacceptable distortion of the received information. The purpose of Automatic Frequency Control is to eliminate these frequency shifts.

3.0 CAUSES OF FREQUENCY ERROR

When a satellite is placed in geosynchronous orbit, the satellite remains at a fixed equatorial longitude. If the geosynchronous satellite is placed so that it is directly over the equator, the latitude of the satellite will also remain constant. This geosynchronous satellite at 0 degrees latitude is called geostationary. While the geostationary orbit is the ideal place to have a satellite, in reality, the effects of the sun and the moon quickly pull the satellite out of a geostationary orbit. In a geosynchronous orbit with latitude other than 0 degrees, the satellite moves back and forth across the equator over the course of the day. The path of the geosynchronous satellite has the shape of a figure eight and has a period of one day.

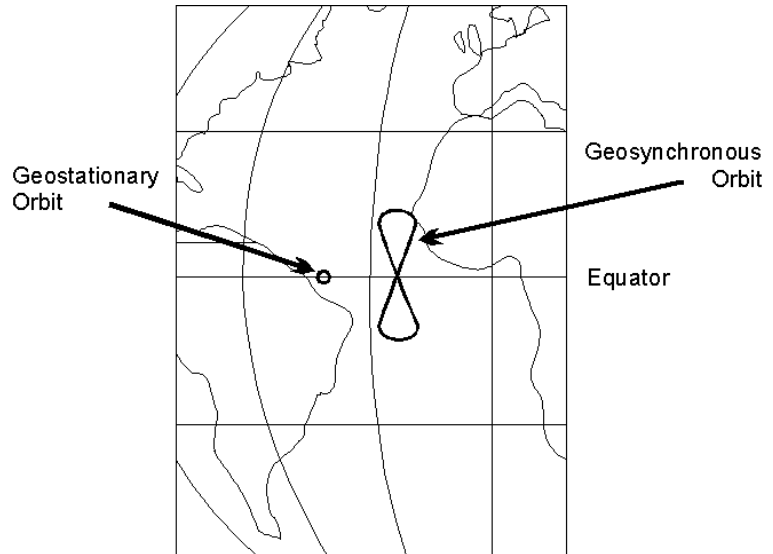

Figure 1. Satellite Movement

The most significant aspect of the satellite's figure eight motion is its North/South movement. As seen from an earth station, this movement results in a continuously changing distance between the earth station and the satellite (range).

This changing distance produces a Doppler effect (frequency shift) on the signals being transmitted to and received from the satellite. Earth stations in different locations will experience different amounts of Doppler effect. Since Doppler is a function of wavelength, carriers at different frequencies will be shifted by different amounts.

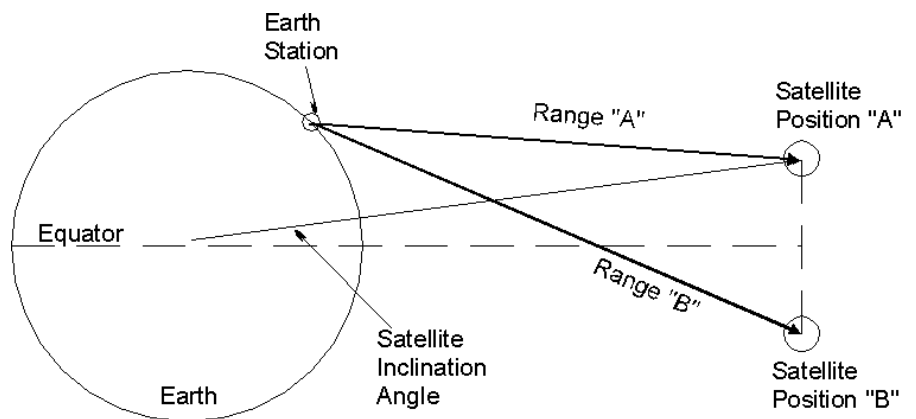

Figure 2. Satellite Range

4.0 THE INMARSAT EAFC SYSTEM

The hardware consists of:

- A. A main earth station transmitting a pilot signal.
- B. A secondary earth station using the pilot as a reference and handling communications traffic.
- C. A mobile terminal generating communications traffic.
- D. A satellite relaying all this information.

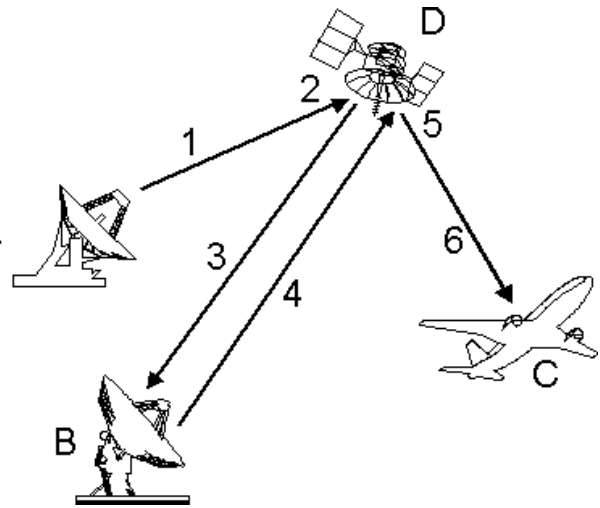

Figure 3. INMARSAT EAFC

There are a number of frequency errors generated:

1. A Doppler shift on the pilot signal transmitted from the main station (A) to the satellite (D).
2. A frequency translation error on the pilot signal in the satellite (D).
3. A Doppler shift on the pilot signal transmitted from the satellite (D) to the secondary station (B).
4. A Doppler shift on the communications signal transmitted from the secondary station (B) to the satellite (D).
5. A frequency translation error on the communications signal in the satellite (D).
6. A Doppler shift on the communications signal transmitted from the satellite (D) to the mobile terminal (C).

The following statements apply:

- The primary earth station (A) and the secondary earth station (B) are each independently able to generate accurate, stable, on-frequency signals.
- Frequency translation error on the pilot signal (2) and frequency translation error on the communications signal (5) are both produced by the same piece of equipment (Satellite 'D'). The change in frequency on the pilot signal is the same as the change

in frequency of the communications signal.

- The Doppler shift on the communications signal transmitted from the satellite (D) to the mobile terminal (C) (frequency error δ) is corrected for at the mobile terminal (C). The earth stations (A&B) cannot detect this Doppler shift. The communications signals transmitted from the mobile terminal (C) to the satellite (D) are at the correct frequency as they enter the satellite (D) because of corrections made at the mobile terminal (C).

The goal of the EAFC system is to ensure:

- That the communications signals transmitted from the satellite (D) to the mobile terminal (C) are at the correct frequency when they leave the satellite (D).
- That the communications signals transmitted from the mobile terminal (C) to the satellite (D) are at the correct frequency at the earth station (B) demodulators.

5.0 CALCULATION OF THE FREQUENCY CORRECTIONS AT THE SECONDARY EARTH STATION

The secondary earth station starts with the following information:

- a) Location of itself (latitude and longitude)
- b) Location of the primary earth station (latitude and longitude)
- c) Location of the satellite (longitude)
- d) Time of day
- e) Uncorrected frequency of the pilot signal

The pilot receiver in the secondary earth station monitors the frequency of the pilot signal transmitted from the primary earth station for a minimum of 24 hours. These data are then analyzed to determine the average error and the periodic error.

The average error is the frequency translation error of the satellite.

The periodic error is the combined Doppler shift (primary earth station to the satellite and satellite to the secondary earth station).

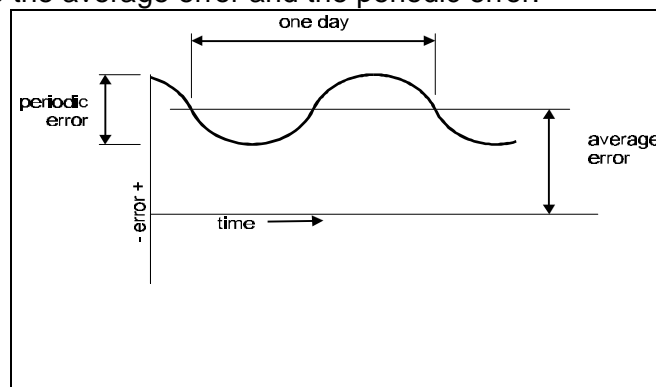

Figure 4. Received Pilot Error

Knowing the combined Doppler shift, the locations of the earth stations, and the frequencies being used, the Doppler shift for signals transmitted from the secondary earth station to the satellite can be calculated.

The terms for the Doppler shift for signals transmitted from the secondary earth station to the satellite and the satellite frequency translation error are used to correct the communications carriers transmitted from the secondary earth station.

In a similar manner, correction terms are calculated for communications carriers transmitted from the satellite to the secondary earth station.

Since the average error and the peak-to-peak periodic error will change slowly over long periods of time, the pilot receiver continuously monitors the pilot frequency and uses the most recent data in calculating correction factors.

6.0 GRAPHICAL COMPARISON OF AFC AND EAFC

Figures 5 and 6 represent the frequency plan for the earth station uplink. Figures 7 and 8 represent the frequency plan for the earth station downlink.

In the non-enhanced AFC, Figures 5 and 7, the Doppler shifts experienced by the satellite links are ignored. This is a 1:1 relationship between the received pilot error and the correction frequency. An analog, phase-locked system may be used to implement this type of AFC. Note that on the down link, a separate uncorrected downconverter channel is required to feed the analog pilot receiver.

In the enhanced AFC (EAFC), Figures 6 and 8, a number of calculations must be performed to extract the Doppler information from the received pilot signal. There is not a 1:1 relationship between the received pilot error and the correction frequency. This type of enhanced AFC is best implemented in a digital system. Note that on the down link, a separate, uncorrected downconverter channel is not required. The digital pilot receiver is able to take the correction frequency into account when measuring the pilot frequency.

Cumulative Frequency Shift

Ref.	Item	Port	Frequency
A	C Band Pilot Generator	Output	0
B	Satellite Link C Band to L Band	Input	0
		Output	+1
C	L Band Down Converter	Input	+1
		Output	+1
D	Pilot Receiver	Input	+1
		Output	-1
E	C Band Up Converter	Input	0
		L.O.	-1
		Output	-1
F	Satellite Link C Band to L Band	Input	-1
		Output	0
G	L Band Terminal	Input	0

Notes:

The satellite links represented by B and F are the same physical equipment being operated at different frequencies.

The Cumulative Frequency Shift chart defines the frequency translation error of the satellite link as one unit of frequency shift.

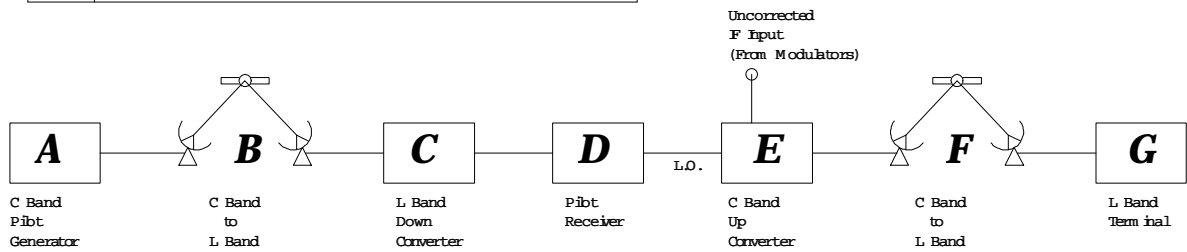

NMARSAT Coast Earth Station Uplink Frequency Correction

(C to L AFC)

Figure 5. AFC Uplink

Cumulative Frequency Shift

Ref.	Item	Port	Frequency
A	C Band Pilot Generator	Output	0
1	Satellite Link C Band Doppler Shift	Input Output	0 +1
D	Satellite Link C Band to L Band	Input Output	+1 +1+D
3	Satellite Link L Band Doppler Shift	Input Output	+1+D +1+D+3
B	L Band Down Converter	Input Output	+1+D+3 +1+D+3
B	Pilot Receiver	Input Output	+1+D+3 -D-4
B	C Band Up Converter	Input L.O. Output	0 -D-4 -D-4
4	Satellite Link C Band Doppler Shift	Input Output	-D-4 -4
D	Satellite Link C Band to L Band	Input Output	-4 0
6	Satellite Link L Band Doppler Shift	Input Output	0 +6
C	L Band Terminal	Input	+6

INMARSAT

Coast Earth Station

Aeronautical Uplink

Frequency Correction

(C to L EAFC)

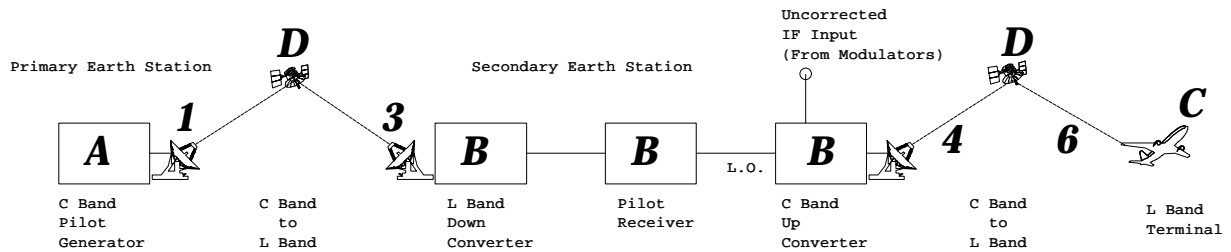

Figure 6. EAFC Uplink

Cumulative Frequency Shift

Ref.	Item	Port	Frequency
A	L Band Pilot Generator	Output	0
B	Satellite Link L Band to C Band	Input	0
		Output	+1
C	C Band Down Converter First Conversion	Input	+1
		Output	+1
D	C Band Down Converter Uncorrected Second Conversion	Input	+1
		Output	+1
E	Pilot Receiver	Input	+1
		Output	-1
F	C Band Down Converter Corrected Second Conversion	Input	+1
		L.O.	-1
		Output	0

Notes:

The Cumulative Frequency Shift chart defines the frequency translation error of the satellite link as one unit of frequency shift.

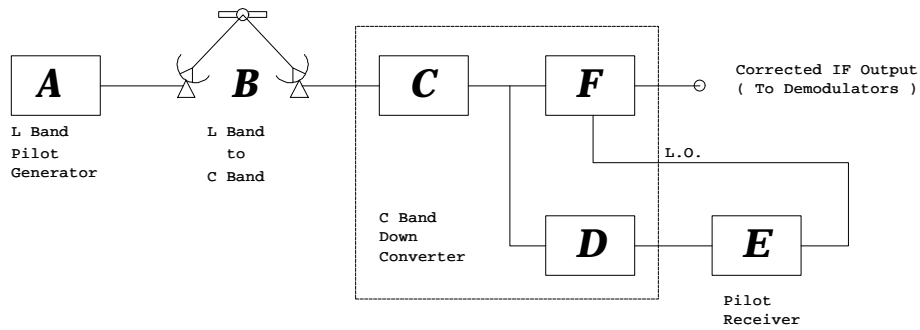

INMARSAT Coast Earth Station Downlink Frequency Correction
(L to C AFC)

Figure 7. AFC Downlink

Cumulative Frequency Shift

Ref.	Item	Port	Pilot Frequency	Traffic Frequency
A	L Band Pilot Generator	Output	0	
C	L Band Terminal	Output		-6
1	Satellite Link	Input	0	
	L Band Doppler Shift	Output	+1	
6	Satellite Link	Input		-6
	L Band Doppler Shift	Output		0
D	Satellite Link	Input	+1	0
	C Band to L Band	Output	+1+D	+D
3,4	Satellite Link	Input	+1+D	+D
	C Band Doppler Shift	Output	+1+D+3,4	+D+3,4
B	C Band Down Converter	Input	+1+D+3,4	+D+3,4
	L.O.	(see note)	(see note)	-D-3,4
	Output	(see note)	(see note)	0
B	Pilot Receiver	Input	+1+D+3,4	
	Output		-D-3,4	
B	Demodulators	Input		0

INMARSAT

Coast Earth Station
 Aeronautical Downlink
 Frequency Correction
 (L to C EAFC)

Notes:

The downconverter output to the pilot receiver is frequency corrected. The pilot receiver calculates the uncorrected frequency.

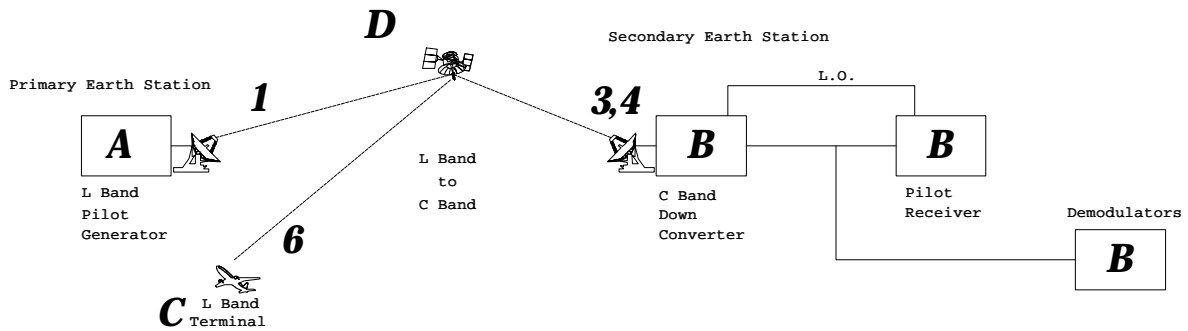

Figure 8. EAFC Downlink